

APEX 230 DIY BOX Specification



Content

1. Scope	4
2. Specifications	4
3. Dimensions and Appearance	5
4. Box accessory	6
5. BMS parameters	7
5.1. Electrical specifications	7
5.2. Basic parameters and function	7
5.3. Status indication	15
5.4. computer software program	16
5.5. Bluetooth	17
5.6. APP Download	17
5.7. Turn on or off	18
5.8. Dimensional location drawing	18
5.9. Reference Diagram and Connection Instructions	19
5.10. Connection definition	20
5.11. Power-on and Power-off Sequence	21
5.12. Communication Description	21
5.13. Parallel Machine Communication	22
5.14. Band address selection (manual dialing method)	23
6. Warranty	27
7. Warnings	27

1. Scope

This product specification applies to the 51.2V 230Ah lithium iron phosphate battery box independently developed by Apexium. The specification stipulates the applicable scope, technical specifications, packaging, transportation, storage and other matters needing attention of this product.

2. Specifications

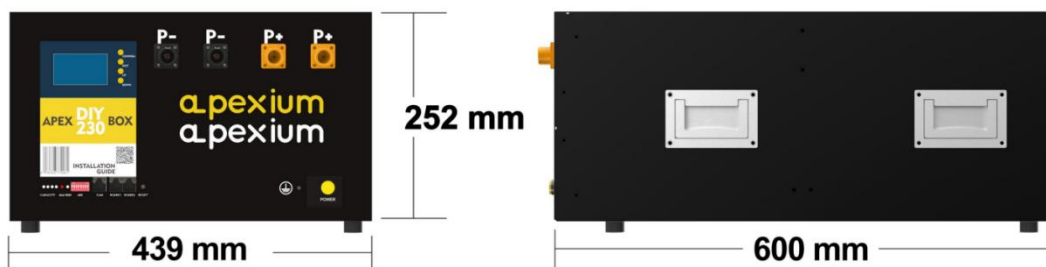

Model	APEX 48V 230 DIY BOX PRO
BMS	APEX - 16S 200A
Display	LCD display
Length、Width、Height(mm)	600×439×252(mm)
Weight(kg)	20(KG)
Suitable for	16 pcs Lifepo4 228Ah 230Ah cells
Material	Iron
Ambient Temperature	-30~55℃
Process	Painting
Thickness(mm)	1.5mm
Distance from Bottom to Ground	20mm
IP level	IP20

3. Dimensions and Appearance



Main Accessories

Name	Quantity(pc)
Pressure Plate	2
Top Cover	1
Front Panel	1
Stopper	1
Positive and Negative Terminals	4

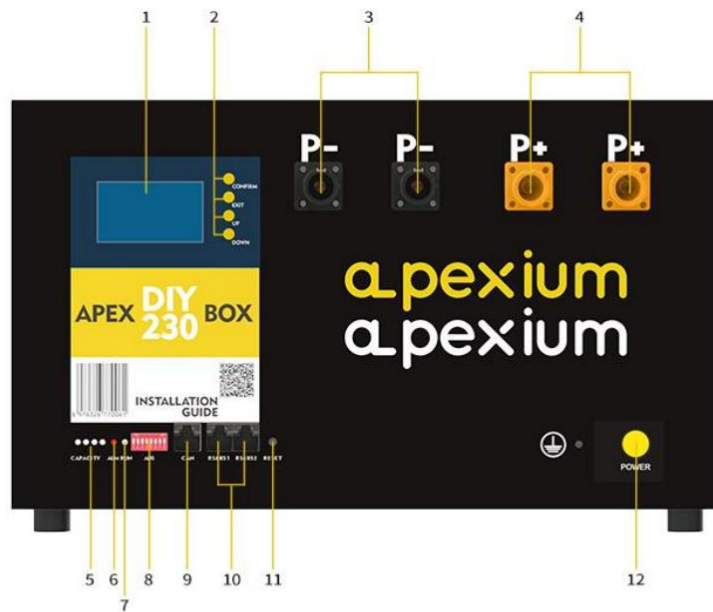

- | | | |
|----------------------|-----------------------------|------------------------------|
| 1. Display screen | 5. Capacity indicator light | 9. CAN communication port |
| 2. Screen button | 6. Alarm light | 10. RS485 communication port |
| 3. Negative terminal | 7. Run light | 11. Reset button |
| 4. Positive terminal | 8. DIP switch | 12. Power switch |

4. Box accessory

Model	Quantity
Apex 48V200A 16S 200A Smart BMS with Bluetooth,support RS485/Can	1
BMS LCD Display screen	1
200* 175*0.7 Epoxy board	4
600* 175*0.7 Epoxy board	2
600*200*0.7 Epoxy board	2
610*60*2 EVA foam	2
180* 160*3.5 EVA foam	20
80V400A Fuse Film	1
80V400A Fuse plate base	1
130*20*2.3,2 hole diameter 8.2 Copper busbar (P+)	1
210*20*2.3, 1 hole diameter 8.2,3 small holes Copper busbar	1
305*20*2.3,2 hole diameter 8.2 Soft copper busbar (P-)	1
270*20*2.3,2 small holes Soft copper busbar(B-)	1
370*20*2.3,4 small holes Soft copper busbar(B+)	1
99*28*2.5 Aluminum row M6 screw hole	15
M6 Copper busbar and nut	1
Positive terminal with waterproof gasket	2
Gegative terminal waterproof gasket	2
160*55*3 Thermal silica gel	1
Front Panel	1
Battery voltage acquisition board	2
Rubber feet	4
Display Panel Sticker	1
6*6*2.8 Tact switch button cap	4
Display Cable	1
Battery collection wire	2
Spring automatic buckle	3
M6 Gasket	32
M6 Nuts	32
M8* 16 bolts	7
M5*8 bolts	8
M6*25 bolts	7
M4*6 bolts	12
M6* 14 bolts	6
M5* 10 bolts	12
M4*8 boltsA	26
M4*8 bolts	16
M3*6 bolts	4
M3* 10 bolts	6

5. BMS parameters

5.1. Electrical specifications

Project	Min	Max	Type	Unit
Normal operating voltage	40	59	48	V
Normal charging voltage	/	60	54	V
Operating temperature range	-20	70	25	°C
Storage environment temperature	-40	85	25	°C
Operating humidity	10	85	/	%
Continuous charging current	/	210	200	A
Continuous discharging current	/	210	200	A
Discharge output impedance	<2			mΩ
Normal operating power consumption	<40			mA
Standby power consumption		50	0	uA

5.2. Basic parameters and function

function name	Function settings	project list	Settings	Set range
Single voltage alarm	turn on	Single high voltage alarm	3500mV	Cell high voltage recovery ~ Cell over voltage protection
		single high pressure recovery	3400mV	3000mV~Single high voltage alarm
	turn on	Single low voltage alarm	2900mV	Cell under-voltage protection ~ Cell low-voltage recovery
		Single low pressure recovery	3100mV	Single unit low voltage alarm ~3300mV

Single over voltage protection	turn on	Single over voltage protection	3650mV	Single high voltage alarm~4500mV
		Single over voltage recovery	3400mV	Cell high voltage recovery ~ Cell over voltage voltage
		Over voltage recovery condition	1. The cell voltage drops to the over voltage recovery point 2. The remaining capacity is lower than 96% of the intermittent recharging capacity. Note: Two conditions must be met to restore	
			It is detected that the battery has a discharge current >3A	
Single under voltage protection	turn on	Under voltage protection voltage	2700mV	1500mV~cell under voltage recovery
		Brown-out recovery voltage	3100mV	Single unit under-voltage protection ~ single unit low-voltage alarm
		Single unit under voltage shutdown	Shut down after under-voltage protection and maintain communication for 1 minute	
		Under voltage recovery conditions	Charging current (>1A) detected	
Battery total voltage alarm	turn on	Total pressure high pressure alarm	56.0V	Total pressure high pressure recovery~Total pressure over voltage protection
		Total pressure high pressure recovery	54.0V	53.0V~total voltage high voltage
	turn on	Low total pressure alarm	46.4V	Total pressure under voltage protection ~ total pressure low pressure recovery

		Total pressure low pressure recovery	48.0V	Total voltage low voltage alarm ~55.0V	
Total voltage over voltage protection	turn on	Total voltage over voltage protection	57.6V	Total voltage high voltage alarm~60.0V	
		Total pressure over voltage recovery	54.0V	Total pressure high voltage recovery ~ total pressure over voltage voltage	
		Over voltage recovery condition	1. The cell voltage drops to the over voltage recovery point 2. The remaining capacity is lower than 96% of the intermittent recharging capacity. Note: Two conditions must be met to restore		
			It is detected that the battery has a discharge current >3A		
Total voltage under voltage protection	turn on	Total voltage under voltage protection	43.2V	36.0V~Total voltage and under voltage recovery	
		Total voltage and under voltage recovery	48.0V	Total pressure under voltage protection ~ total pressure low pressure alarm	
		Total voltage under voltage shutdown	Shut down after under-voltage protection and maintain communication for 1 minute		
		Under voltage recovery conditions	Charging current (>1A) detected		
Battery core temperature prohibits charging	turn on	Charging high temperature alarm	50°C	Charging high temperature recovery ~ charging over-temperature protection	
		Charging high temperature recovery	47°C	35°C~ charging high temperature alarm	

		Charging over-temperature protection	55°C	Charging over temperature recovery ~80°C
		Charging over-temperature recovery	50°C	Charging high temperature recovery ~ charging over-temperature protection
		Charging low temperature warning	2°C	Charging under temperature protection ~ charging low temperature recovery
		Charge low temperature recovery	5°C	Charging low temperature warning ~10°C
		Charging under temperature protection	-10°C	-20°C ~charging under-temperature recovery
		Charge under temperature recovery	0°C	Charging under temperature protection ~ charging low temperature recovery
Cell temperature forbidden	turn on	Discharge high temperature alarm	52°C	Discharge high temperature recovery~Discharge over-temperature protection
		Discharge high temperature recovery	47°C	35°C ~discharge high temperature alarm
		Discharge over temperature protection	55°C	Discharge over-temperature recovery ~80°C
		Discharge over temperature recovery	50°C	Discharge high temperature recovery~Discharge over-temperature protection
		Discharge low temperature warning	-10°C	Discharge under temperature protection ~ discharge low temperature recovery
		Discharge low temperature recovery	3°C	Discharge low temperature alarm ~10°C
		Discharge under temperature protection	-15°C	-30°C ~discharge under-temperature recovery

		Discharge under temperature recovery	0°C	Discharge under temperature protection ~ discharge low temperature recovery
Ambient temperature protection	turn on	Ambient high temperature warning	50°C	Environmental high temperature recovery~Environmental over-temperature protection
		Environmental high temperature recovery	47°C	-20°C~environmental high temperature alarm
		Environmental over-temperature protection	60°C	Ambient over-temperature recovery ~80°C
		Environment over-temperature recovery	55°C	Environmental high temperature recovery~Environmental over-temperature protection
		Ambient low temperature warning	0°C	Environmental low temperature protection~environmental low temperature recovery
		Ambient low temperature recovery	3°C	Ambient low temperature warning ~60°C
		Environmental under temperature protection	-10°C	-30°C~Environment low temperature recovery
		Environmental under temperature recovery	0°C	Environmental low temperature protection~environmental low temperature recovery
power temperature protection	turn on	Power high temperature warning	90°C	Power high temperature recovery ~ power over temperature protection
		Power High Temperature Recovery	85°C	60°C~ power high temperature alarm

		Power over temperature protection	100°C	Power high temperature alarm ~ 120°C
		Power over temperature recovery	85°C	Power high temperature recovery ~ power over temperature protection
Charge current limit	closure	Active current limiting	10A	Charger current is greater than 10A, open current limit
	turn on	Passive current limiting		The charger current is greater than the charging over current alarm (note: the value can be set), and the current limit is turned on.
		Charging current limit delay	5 minutes	After the current limit is enabled, re-check whether the current limit is enabled after 5 minutes
Charging over current alarm	turn on	Charging over current alarm	200A	Charging over current recovery ~ charging over current protection
		Charging over current recovery	195A	0A~charging over current alarm
Charging over current protection	turn on	Charging over current protection	210A	Charging over current warning ~250A
		Charging over current delay	10S	0S~ 10S
		Over current recovery condition	Discharge resumes immediately, or automatically after 60S	
Effective charging current	Charging into the current		600mA	
	Charge Exit Current		500mA	
Discharge over current	turn on	Discharge over current alarm	-205A	Discharge over current protection ~ discharge over current recovery

alarm		discharge over current recovery	-203A	Discharge over current alarm~0A
Discharge over current protection	turn on	Discharge over current protection	-210A	Transient over current protection ~ discharge over current alarm
		Discharge over current delay	10S	0S~ 10S
		Over current recovery condition	Charging resumes immediately, or automatically after 60S	
Transient over current protection	turn on	Transient over current protection	-300A	Discharge over current protection value~300A
		Transient over current delay	30M	0mS~ 100mS
		Transient over current recovery	Charging resumes immediately, or automatically after 60S	
	closure	Transient over current lockout	Continuous two-level over current, exceeding the number of over current lockouts	
		Number of over current lockouts	5 times	
		Momentary lock release	Connect the charger	
Output short circuit protection	turn on (Currently does not support off settings)	Short circuit protection current and time delay	Write program (note: not settable)	
		short circuit protection recovery	Charging resumes immediately, or automatically after 60S	
	turn on	Short circuit protection lockout	Continuous output short circuit, exceeding the number of over-current lockouts	
		Short circuit lockout times	5 times	
		Short circuit lock release	Connect the charger	
Effective	discharge into current		-500mA	

discharge current	Discharge exit current	-400mA			
Cell balancing function	turn on	Standby equalization	Turn on equalization in no charging and discharging state		
		Standby equalization time	10 hours	Can be set	
	turn on	Charge balancing	Turn on equalization in charging state and float charge state		
	Turn on voltage condition	Balanced turn-on voltage	3400mV	Can be set	
		Balanced opening pressure difference	30mV		
		Equilibrium end pressure difference	20mV		
	turn on	Equilibrium Temperature Limit	According to (note: determined by the ambient alarm temperature) the balanced shutdown temperature range		
		Equilibrium high temperature prohibited	50°C	Can be set	
		Equilibrium Low Temperature Prohibition	0°C		
	Battery core failure alarm	turn on	Cell failure voltage difference	500mV	Can be set
Cell recovery voltage difference			300mV		
Battery capacity setting	Battery rated capacity		200Ah	5Ah~300Ah	
	Battery remaining capacity		Estimate dby cell voltage	Can be set	
	Cycle Cumulative Capacity		80%	Number of cycles (configurable)	

	turn on	Remaining capacity warning	15%	
	turn on	Reserved capacity protection	5%	close output
PRE charge function	2000ms	0~5000ms can be set	BMS starts the PRE charging function instantly when it is turned on	
BMS power consumption management	turn on	Maximum standby time	48h (the charger is not in and there is no effective discharge current)	
Battery core low temperature heating	turn on	Battery core low temperature heating	0°C	Can be set
		Battery core heating recovery	10°C	
		Heating start logic	When the charger is online and the temperature of the battery core reaches the opening condition, turn on the heating. No heating in standby state and discharge state	
external switch	turn on	When the BMS is in standby mode, the external switch can be operated to turn off and turn on the BMS		
LCD screen	turn on	Simplified monitoring software, you can view data such as battery cells, temperature, current, etc.		
Manual charging activation	turn on	1 point	After the under voltage protection, the BMS shuts down, manually press the button to activate and clear the forced output of the under voltage protection	Can be set
Compensation impedance	Compensation point 1	0mΩ	9	Can be set
	Compensation point 2	0mΩ	13	

5.3. Status indication

system	Operating	RUN	ALM	SOC	illustrate
--------	-----------	-----	-----	-----	------------

status	status	●	●	●	●	●	●	
shutdown	sleep	off	off	off	off	off	off	wipe out
standby	normal	Flash 1	off	off	off	off	off	standby mode
Charge	normal	Always on	off	According to the battery indicator				Highest LED Flash 2
	Over current warning	Always on	Flash 2	According to the battery indicator				Highest LED Flash 2
	Over voltage protection	Flash 1	off	off	off	off	off	
	temperature, over current protection	Flash 1	Flash 1	off	off	off	off	
discharge	normal	Flash 3	off	According to the battery indicator				Steady light indicator based on power
	alarm	Flash 3	Flash 3					
	Temperature, over current, short circuit, etc. protection	off	Always on	off	off	off	off	Stop discharging. When the mains power is offline, there will be no action after 48 hours to force sleep.
	under voltage protection	off	off	off	off	off	off	Stop discharging

5.4. computer software program

You can modify and store related parameters and data through computer software programs.

Storage content includes: protection and alarm, their categories, recovery time of protection and alarm, voltage of single cell, total voltage of battery pack, charge/discharge capacity, charge/discharge current, temperature, etc. Recorded in year/month/day/hour/minute/second format, or through settings, information content within a certain time period can also be recorded. The storage capacity of information is not less than 300 entries. Historical data can be read through the host computer and saved as an excel file to the computer.

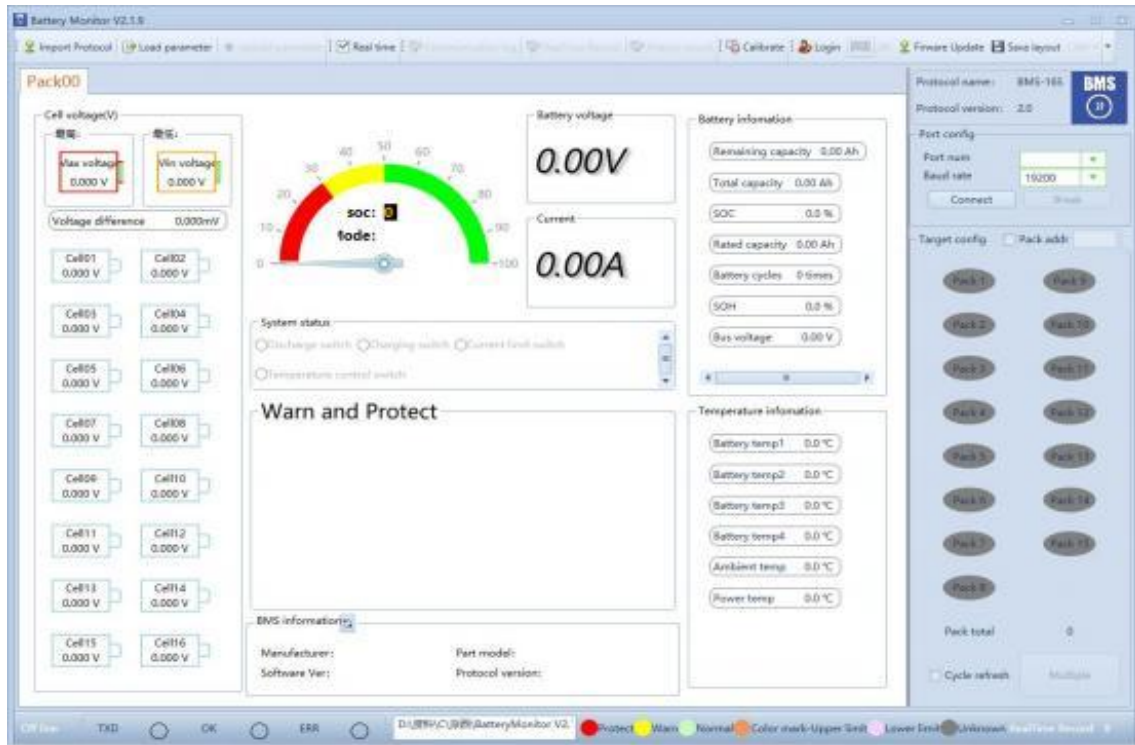

5.5. Bluetooth

This BlueTooth APP can be operated by both Android and IOS. It establish a BlueTooth connection between your smart phone and the battery, usages includes below: managing the battery pack, gathering the data and displaying them, conducting modifications on settings.

BlueTooth APP can achieve below functions:

- 1) Display the basic data of battery pack
- 2) Modifying the communication between BMS and inverter
- 3) Setting Alert Parameters and Switch on/off
- 4) Support Single and Parallel operation
- 5) Shift between Chinese and English

5.6. APP Download

Scan the QR code to download BMS APP



Android



IOS

5.9. Reference Diagram and Connection Instructions

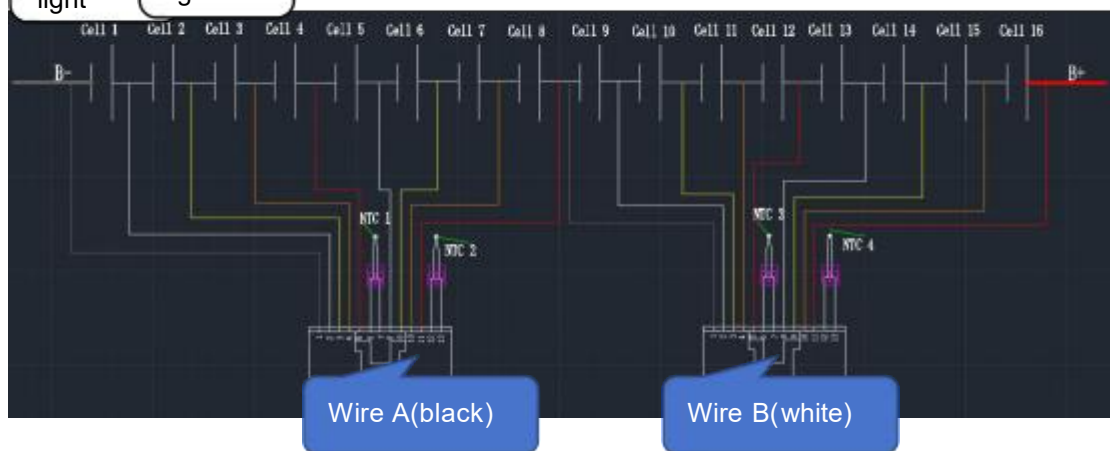
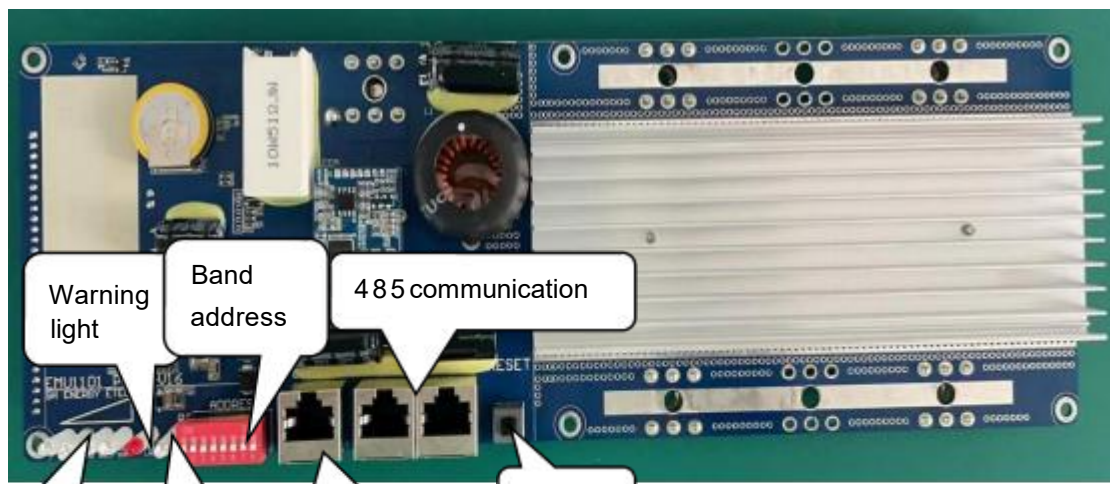
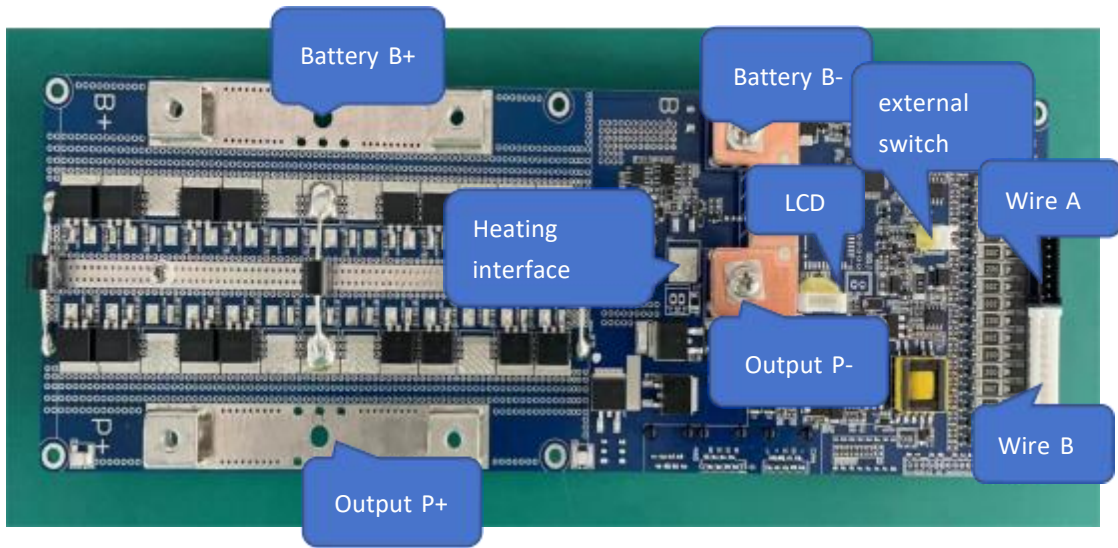

5.10. Connection definition

Wire A (black)		
	CELL1-	Negative of the first battery
	CELL1+	Positive of the first battery
	CELL2+	Positive of the 2nd battery
	CELL3+	Positive of the 3rd battery
	CELL4+	Positive of the 4th battery
	NTC1+	Connect NTC1
	NTC1-	Connect NTC1
	CELL5+	Positive of the 5th battery
	CELL6+	Positive of the 6th battery
	CELL7+	Positive of the 7th battery
	CELL8+	Positive of the 8th battery
	NTC2+	Connect NTC2
	NTC2-	Connect NTC2

Wire B (white)		
	CELL9-	Negative of the 9th battery
	CELL9+	Positive of the 9th battery
	CELL10+	Positive of the 10th battery
	CELL11+	Positive of the 11th battery
	CELL12+	Positive of the 12th battery
	NTC3+	Connect NTC3
	NTC3-	Connect NTC3
	CELL13+	Positive of the 13th battery
	CELL14+	Positive of the 14th battery
	CELL15+	Positive of the 15th battery
	CELL16+	Positive of the 16th battery
	NTC4+	Connect NTC4
	NTC4-	Connect NTC4

Note: CELL8+ and CELL9- are connected to the positive electrode of the 8th cell and the negative electrode of the 9th cell, providing sampling accuracy for the cell; CELL16+ is the B+ end of the cell.

5.11. Power- on and Power- off Sequence

- 1) Power-on sequence: First connect the main board B-, then connect the wiring harness A, followed by the wiring harness B, then connect the main board B+, and finally connect the P+ and P- to the charger or load (Note: The main board is in off state after connecting the wires, press the reset button to turn on or close the external switch, charging can also activate the BMS).
- 2) Power-off sequence is completely opposite: First disconnect the charger or load (Note: Press the 6S reset button or disconnect the external switch, the flow indicator lights will turn off once to shut down), then disconnect B+, sequentially disconnect the wiring harness B, then disconnect the wiring harness A, and finally disconnect B-.
- 3) Input and Output During charging: The positive terminal of the charger is connected to the "P+" of the protection board, and the negative terminal of the charger is connected to the "P-" of the protection board. During discharging: The positive terminal of the load is connected to the "P+" of the protection board, and the negative terminal of the load is connected to the "P-" of the protection board.

5.12. Communication Description

- 1) CAN and RS485 Communication The BMS has a battery group upload CAN communication function with a baud rate of 500K. The CAN communication interface uses an 8P8C network cable interface. Through the CAN interface, it can communicate with the inverter or CAN TEST. When the battery group is assembled, it is connected through RS485 communication, and finally uploads the battery group data, status, and information to PCS through CAN communication.
- 2) The BMS has a battery group upload RS485 communication function with a baud rate of 9600bps. The RS485 communication interface uses an 8P8C network cable interface. When the battery group is assembled, it is connected through RS485 communication, and finally uploads the battery group data, status, and information to PCS or inverter through RS485 communication.
- 3) CAN communication is based on the protocol of each inverter for communication and can connect to inverters for communication. (Note: It is compatible with PaiNeng, GoodWe, Deye, PengCheng, TBB by default, and can switch to Gruidel, Victron, SMA, ShouHang, JinLang, Studer) RS485 communication is based on the protocol of each inverter for communication and can connect to inverters for communication. (Note: It can automatically identify the protocols of PaiNeng, Gruidel, ShuoRi)

Definition of CAN and RS485 communication interfaces:

CAN:

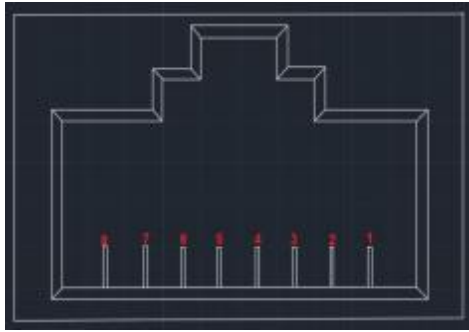

PIN	Definition
1、 8	RS485-B
2、 7	RS485-A
4	CAN-H
5	CAN-L
3、 6	GND

RS485

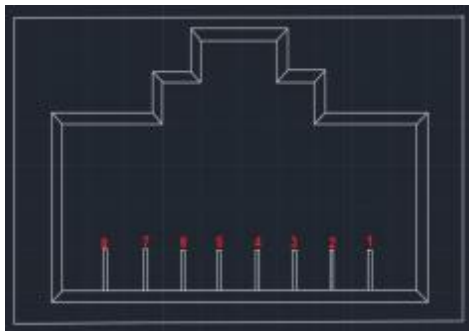

PIN	Definition
1、 8	RS485-B
2、 7	RS485-A
3、 6	GND
4、 5	NC

5.13. Parallel Machine Communication

When multiple machines are paralleled, the RS485 interface serves as the parallel communication interface, and the CAN interface serves as the upper communication interface. The terminal device can read the sum of all battery data from the parallel PACKS through the CAN interface. When multiple machines are paralleled, the connection of the RS485 interface is shown in the following diagram:

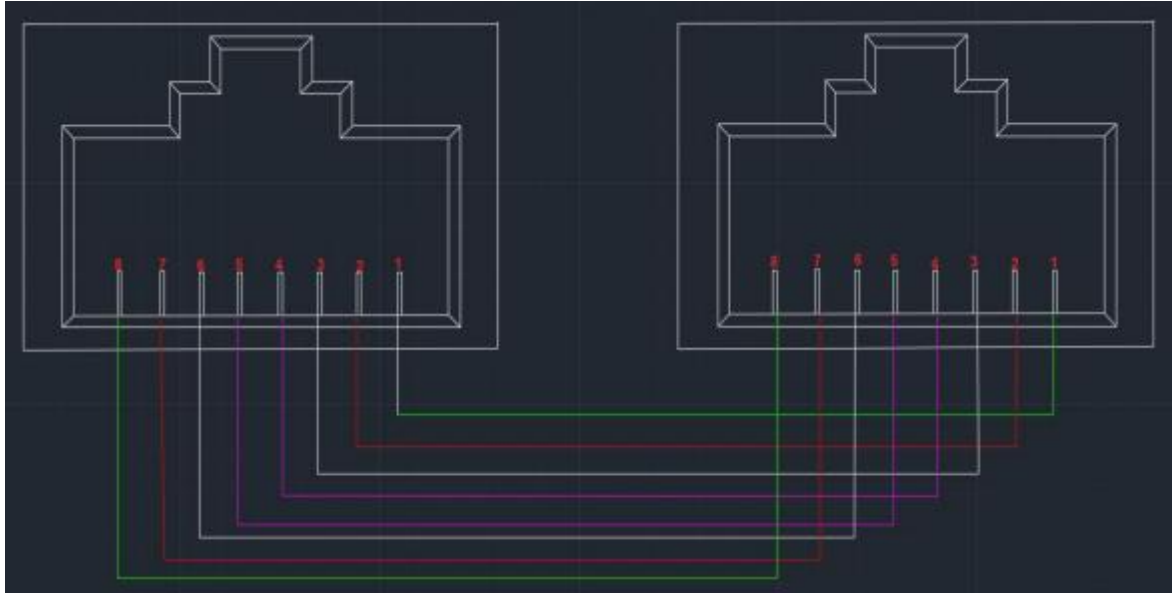

5.14. Band address selection (manual dialing method)

1) **Definition of paralleling switch:** In the case of parallel connection of battery packs, multiple machine communication is used, and the switch is used to distinguish different Pack addresses. The hardware address can be set through the switch on the board. (Note: Support for 8 groups of paralleling is included, while 16 groups require special requests, with default being 8 groups)

2) **Definition of DIP switch bits 1 to 8:** bits 1 to 4 are used to set the address, and bits 5 to 8 are used for the number of slave devices.

Host setting: bits 1 to 4 are set to 0, and the host address is fixed at 0. Bits 5 to 8 are set according to the number of parallel connected slave devices. (See Table 2)

Slave setting: bits 1 to 4 are set according to the device order, with slave address ranging from 1 to 15. Bits 5 to 8 are fixed at 0. (See Table 1)

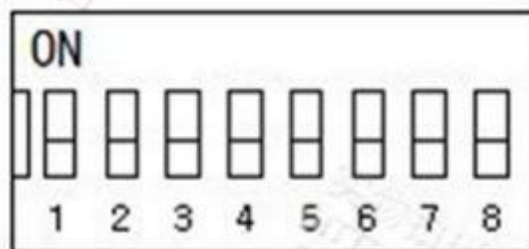

Slave Setup (Table 1)

Address	Band switch position				Explanation
	#1	#2	#3	#4	
1	ON	OFF	OFF	OFF	Pack1
2	OFF	ON	OFF	OFF	Pack2
3	ON	ON	OFF	OFF	Pack3
4	OFF	OFF	ON	OFF	Pack4
5	ON	OFF	ON	OFF	Pack5
6	OFF	ON	ON	OFF	Pack6
7	ON	ON	ON	OFF	Pack7
8	OFF	OFF	OFF	ON	Pack8
9	ON	OFF	OFF	ON	Pack9
10	OFF	ON	OFF	ON	Pack10
11	ON	ON	OFF	ON	Pack11
12	OFF	OFF	ON	ON	Pack12
13	ON	OFF	ON	ON	Pack13
14	OFF	ON	ON	ON	Pack14
15	ON	ON	ON	ON	Pack15

Host setting(Table 2)

Number	Band switch position				Explanation
	#5	#6	#7	#8	
2	ON	OFF	OFF	OFF	2Parallel
3	OFF	ON	OFF	OFF	3Parallel
4	ON	ON	OFF	OFF	4Parallel
5	OFF	OFF	ON	OFF	5Parallel
6	ON	OFF	ON	OFF	6Parallel
7	OFF	ON	ON	OFF	7Parallel
8	ON	ON	ON	OFF	8Parallel
9	OFF	OFF	OFF	ON	9Parallel
10	ON	OFF	OFF	ON	10Parallel
11	OFF	ON	OFF	ON	11Parallel
12	ON	ON	OFF	ON	12Parallel
13	OFF	OFF	ON	ON	13Parallel
14	ON	OFF	ON	ON	14Parallel
15	OFF	ON	ON	ON	15Parallel

Example of parallel machine dial code setting

Number	Band switch position								Explanation	
	#1	#2	#3	#4	#5	#6	#7	#8		
1p	OFF	OFF	OFF	OFF	OFF	OFF	OFF	OFF	OFF	1p
2p	OFF	OFF	OFF	OFF	ON	OFF	OFF	OFF	OFF	First mainframe
	ON	OFF	OFF	OFF	OFF	OFF	OFF	OFF	OFF	Second slave machine
3p	OFF	OFF	OFF	OFF	OFF	ON	OFF	OFF	OFF	First mainframe
	ON	OFF	OFF	OFF	OFF	OFF	OFF	OFF	OFF	Second slave machine
	OFF	ON	OFF	OFF	OFF	OFF	OFF	OFF	OFF	Third slave machine
}	}	}	}	}	}	}	}	}	}	}
}	}	}	}	}	}	}	}	}	}	}
16p	OFF	OFF	OFF	OFF	ON	ON	ON	ON	ON	First mainframe
	ON	OFF	OFF	OFF	OFF	OFF	OFF	OFF	OFF	Second slave machine
	OFF	ON	OFF	OFF	OFF	OFF	OFF	OFF	OFF	Third slave machine
	ON	ON	OFF	OFF	OFF	OFF	OFF	OFF	OFF	Fourth slave machine
	OFF	OFF	ON	OFF	OFF	OFF	OFF	OFF	OFF	Fifth slave machine
	ON	OFF	ON	OFF	OFF	OFF	OFF	OFF	OFF	Sixth slave machine
	OFF	ON	ON	OFF	OFF	OFF	OFF	OFF	OFF	Seventh slave machine
	ON	ON	ON	OFF	OFF	OFF	OFF	OFF	OFF	Eighth slave machine
	OFF	OFF	OFF	ON	OFF	OFF	OFF	OFF	OFF	Ninth slave machine
	ON	OFF	OFF	ON	OFF	OFF	OFF	OFF	OFF	Tenth slave machine
OFF	ON	OFF	ON	OFF	OFF	OFF	OFF	OFF	Eleventh	

									slave machine
	ON	ON	OFF	ON	OFF	OFF	OFF	OFF	Twelfth slave machine
	OFF	OFF	ON	ON	OFF	OFF	OFF	OFF	Thirteenth slave machine
	ON	OFF	ON	ON	OFF	OFF	OFF	OFF	Fourteenth slave machine
	OFF	ON	ON	ON	OFF	OFF	OFF	OFF	Fifteenth slave machine
	ON	ON	ON	ON	OFF	OFF	OFF	OFF	Sixteenth slave machine

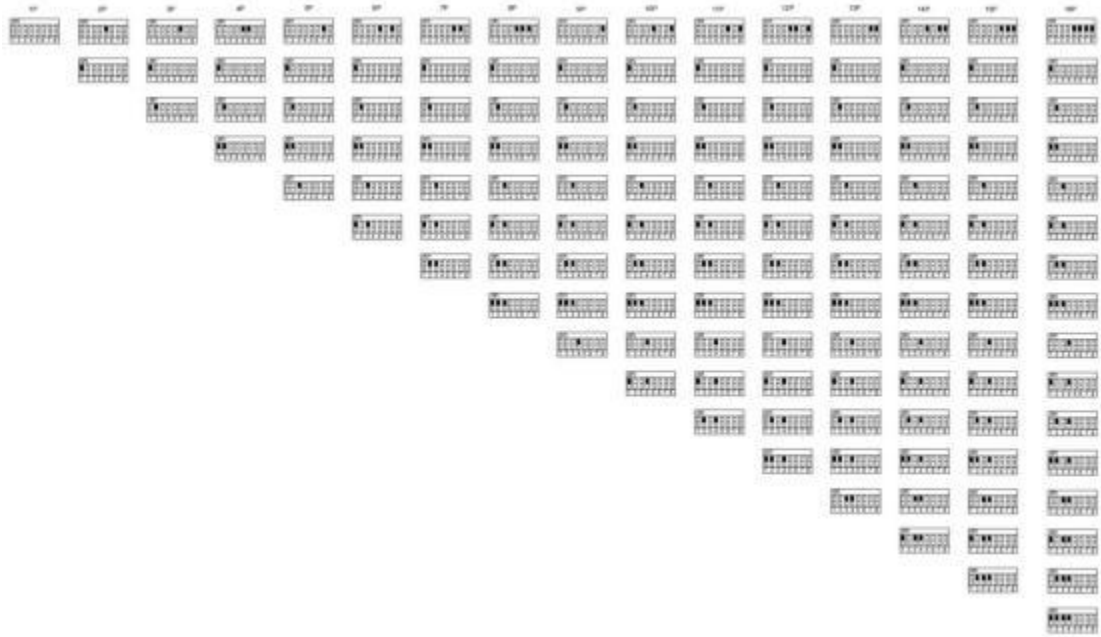

6. Warranty

15 days free replacement:

Manufacturing defect bases

1-11 years free repair

Problem develop with normal use bases

Battery with 5 years warranty

BMS with 1 years warranty

Battery pack with 11 years warranty

Limited lifetime warranty

If problems develop out of free repair period,we will charge for parts.

7. Warnings

- (1) Do not use the battery if it has been pounded or if there is noticeable deformation.
- (2) Do not stack and assemble the batteries. Please be aware of the polarity of the battery and the connection ends.
- (3) Insulate equipment and utilize the tools and instruments properly.
- (4) Battery installation place should be away from fire source or any combustible objects. Make sure there is air flow and the air is dry enough in the place.
- (5) Plugging kits while the product is operating is strictly forbidden.
- (6) Employees other than technicians of our company is prohibited to operate any function module. Anyone violating the rule is at your own.
- (7) Please fully charge the battery with specific charger before using new batteries or using for a long duration.
- (8) Do not disassemble, open, squeeze, bend, deform, pierce or break the product.
- (9) Do not try to retrofit or plug in any exterior objects. Do not soak or expose the product in liquid such as salt or fresh water, beverage (coffee, juice and so on). Keep it away from fire source, explosive material or other dangers.
- (10) Do not short-circuit the battery. Do not let the battery connection ends have any contact with metal or other conductors.
- (11) Do not drop the battery. If it does happen (especially hitting a hard ground), please contact the service center.
- (12) If there is any electrolyte leakage, do not let the battery have any contact with skin or eyes. If it does happen, flow the contact area with large quantity of fresh water or asking for medical stuff.
- (13) Do not disassemble the cell battery in any circumstance. It may lead to interior short circuit, even fire or other problems.
- (14) Do not burn the battery or put it to the fire in any circumstance. Otherwise, the battery may get into fire.