

apexium

Battery Pack Series User Manual



1. Product Description

Lifepo4 lithium battery belongs to one of the series of household energy storage products that are independently designed and developed. It has long cycle life, high safety standard BMS software protection and strong housing, exquisite looks, and easy installation, etc. It is widely used in energy storage system with off- grid inverters, on-off

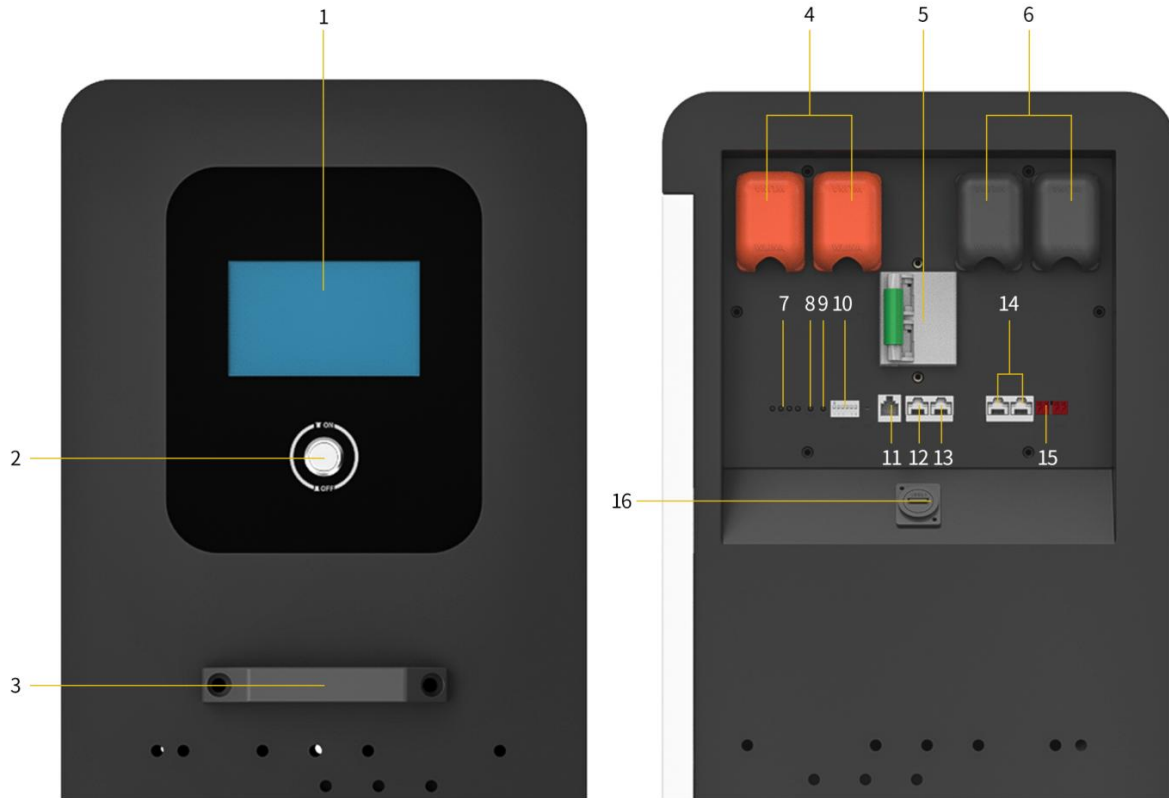

NO.	NAME	FUNCTION
1	touch screen display	Real time display of battery status on touch LCD screen
2	Power Swith	Display screen that can be turned on or off
4	Positive terminal	Battery output positive pole or parallel positive pole circuit
5	AIR breaker	Control the opening and closing of the battery
6	Negative terminal	Display screen that can be turned on or off
7	SOC	The number of lights represents the percentage of battery life
8.9	ALM/RUN	Alarm indicator light/normal operation indicator light
10	RST	Activate/sleep BMS
11	RS232	communication interface
12.13	RS485/CAN	communication interface
14	RS485A/B	communication interface
15	DRY	dry contact
16	WiFi	Connect the WiFi module

2. Product Function Description

2.1 Product Specifications

Items		Condition			
Nominal Capacity		Standard charge/discharge	300.0Ah	600.0Ah	900.0Ah
Nominal Voltage		Average	51.2V	51.2V	51.2V
Charging Voltage		/	58.4V	58.4V	58.4V
Max.Continuous Charge Current		25±3. C	100.0A	100.0A	100.0A
minimum discharging voltage		Constant current End voltage(Cut off)	40V	40V	40V
Max Continuous Discharge Current		25±3. C	200.0A	200.0A	200.0A
MAX Output Power Rate		25±3. C	30720Wh	11776Wh	46080Wh
Operating Temperature	Charge	/	0. C~60. C		
	Discharge	/	-20. C~60. C		
Storage Temperature		1 month 3 month 6month	-20. C~45. C -20. C~35. C -20. C~25. C		
Power Cable Terminal		/	Ring Terminal		

2.2 Parallel Connection

When connecting batteries in parallel, connect the positive terminal and positive terminal (red) in parallel, and the negative terminal and negative terminal (black) in parallel. The maximum number of parallel connections is 16, as shown in the following

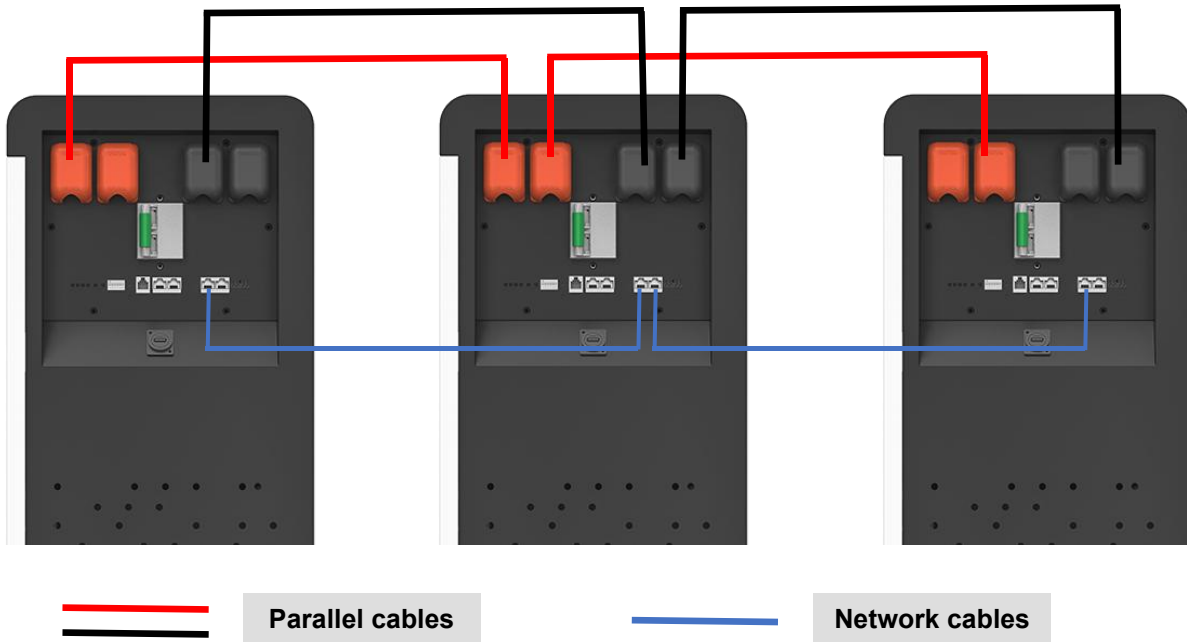

Up to 16 parallel groups

Model	Power	Max parallel	Max power
51.2V300Ah	15360Wh	16pcs	51.2V4800Ah 245.76Kwh
51.2V600Ah	30720Wh	16pcs	51.2V9600Ah 520Kwh
51.2V900Ah	46080Wh	16pcs	51.2V14400Ah 737.280Kwh

3. Communication instructions

3.1 RS232 Communication

BMS can communicate with the upper computer through RS232 interface, so as to monitor various information of the battery, including battery voltage, current, and temperature, through the upper computer, The default baud rate for degree, status, and battery production information is 9600bps.

3.2 CAN Communication

The default baud rate is 500K, and this interface is used for communication with the inverter. When the battery is the host, it can summarize data from the slave and communicate with the inverter.

3.3 Parallel RS485 Communication

You can view the information of PACK, and the default baud rate is 9600bps. If communication with monitoring equipment is required through RS485, the monitoring equipment serves as the host and is based on the location Address polling data, with address settings ranging from 2 to 15.

3.4 Independent RS485 Communication

The default baud rate is 9600bps. This interface is used for communication with the inverter. When the battery is the host, it can aggregate data from the slave and communicate with the inverter.

3.5 Bluetooth Communication

BMS can communicate with Peicheng Bluetooth APP through Bluetooth to monitor various information of the battery, including battery voltage, current, temperature, status, SOC, SOH, and battery production information, etc. The default baud rate is 9600bps.

3.6 WiFi Communication

Press and hold the reset button for 10-13 seconds. After all the flow lights are on, it will turn into a state where one light is on. Release it (except for ON/OFF lights) and wait for 8 seconds to add it to the APP

I see a new device at the equipment location.

3.7 Dial switch setting

When PACKs are used in parallel, different PACKs can be distinguished by setting the address through the dip switch on the BMS. It is necessary to avoid setting the address to be the same and dialing the BMS

The definition of the switch refers to the table below. In parallel mode, the default dialing address is 1 for the host.

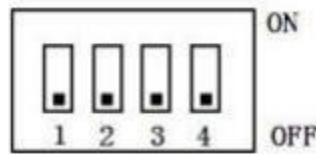

address	Dial switch position			
	#1	#2	#3	#4
0	OFF	OFF	OFF	OFF
1	ON	OFF	OFF	OFF
2	OFF	ON	OFF	OFF
3	ON	ON	OFF	OFF
4	OFF	OFF	ON	OFF
5	ON	OFF	ON	OFF
6	OFF	ON	ON	OFF
7	ON	ON	ON	OFF
8	OFF	OFF	OFF	ON
9	ON	OFF	OFF	ON
10	OFF	ON	OFF	ON
11	ON	ON	OFF	ON
12	OFF	OFF	ON	ON
13	ON	OFF	ON	ON
14	OFF	ON	ON	ON
15	ON	ON	ON	ON

4. Interface definition

4.1 Interface diagram

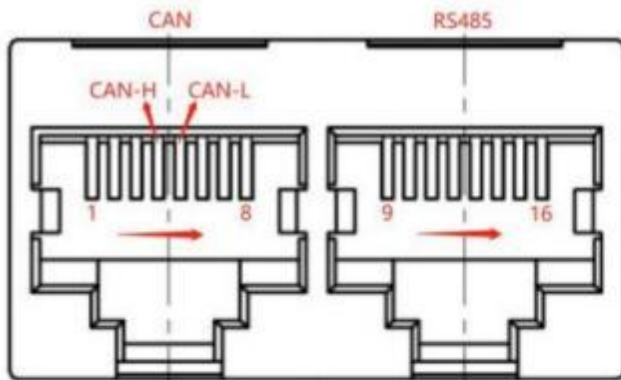

CAN and RS485 interfaces



1 2 3 4

DRY CONTACT

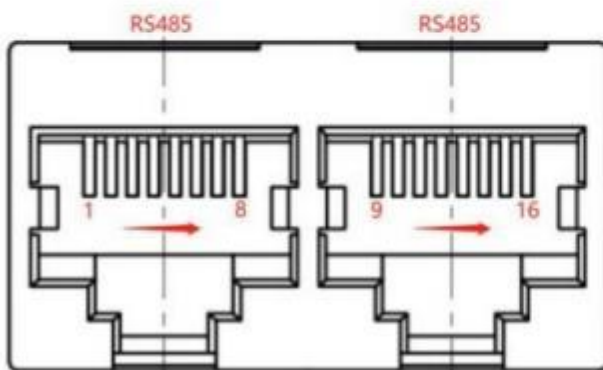

Parallel communication port

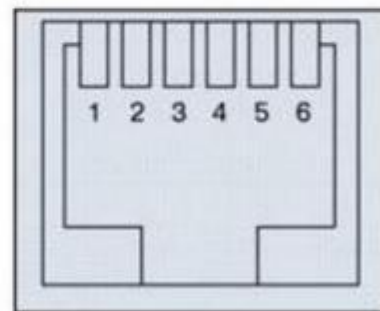

RS232 communication interface

5. Tools

To install the battery pack, those following tools are probably required:

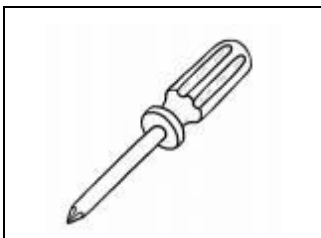

screwdriver



wrench



Cable crimping pliers

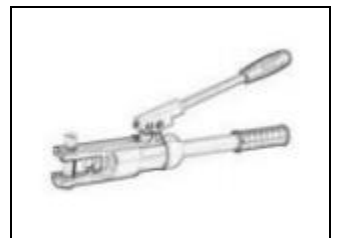

clamp



voltmeter



electric drill



Flat head screwdriver

In order to protect operator and installer' s safety, please select and use suitable tools and measuring instruments that are certified for precision and accuracy.

5.1 Safety Instruments

When dealing with the battery, following safety gears should be equipped. Installers must meet the relevant requirements of IEC 60364 or the domestic legislation and other relevant international standards.



Oven Mitt

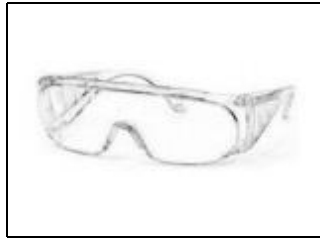

goggles

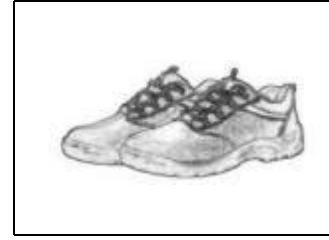

Safety shoes

6 Connection of the wires safely



Wear safety gloves and wrap the positive and negative wires with insulating tape to prevent short circuits caused by contact between the positive and negative poles.



The insulation tape is wrapped around both ends of the positive and negative wires to complete the state



Unscrew the positive screw with a screwdriver



Connect the positive wire



Cover the positive electrode with a protective cover after assembly



Unscrew the negative screw with a screwdriver



Connect the negative wire



Cover the negative electrode with a protective cover after assembly



Battery positive and negative pole installation completed status



Connect the positive wire of the inverter



Connect the negative wire of the inverter



Inverter positive and negative pole installation completed status



Turn on the battery main switch



Activate battery switch



To complete the above steps, wait for one minute before starting the inverter switch

7 LED Indication Function

The current power consumption and operation status of the product are shown through LED indicator Light (See Table 1, Table 2, and Table 3 for details) Working status indication

state	Normal/Alarm/P rotection	ON/ OFF	RUN	ALM	Power indicator LED						describe
					L6	L5	L4	L3	L2	L1	
		●	●	●	●	●	●	●	●	●	
Power Off	Sleep	OFF	OFF	OFF	OFF	OFF	OFF	OFF	OFF	OFF	All off
Standby	normal	ON	Flash1	OFF	Indication by SOC						Standby
	Alarm	ON	Flash1	Flash3							Cell low voltage
Charge	normal	ON	ON	OFF	Indication by SOC(The top soc Led Flash 2)						Maximum power LED flash(flash 2),ALM does not flash for over-charge warning
	Alarm	ON	ON	Flash3							
	Over Charge Protection	ON	ON	OFF	ON	ON	ON	ON	ON	ON	If no mains supply, LED as standby
	Temperature, Over-current Fault Protection	ON	OFF	ON	OFF	OFF	OFF	OFF	OFF	OFF	OFF
Discharge	normal	ON	Flash3	OFF	Indication by SOC						
	Alarm	ON	Flash3	Flash3							
	Under Discharge Protection	ON	OFF	OFF	OFF	OFF	OFF	OFF	OFF	OFF	Close discharge
	Temperature, overcurrent, short circuit Reverse connection, failure protection	ON	OFF	ON	OFF	OFF	OFF	OFF	OFF	OFF	OFF
Fault		OFF	OFF	ON	OFF	OFF	OFF	OFF	OFF	OFF	Close charge Close discharge

Capacity Indicator

State		Charge						discharge					
Capacity indicator light		L6	L5	L4	L3	L2	L1	L6	L5	L4	L3	L2	L1
Electricity consumption (%)	0-17%	OFF	OFF	OFF	OFF	OFF	flash 2	OFF	OFF	OFF	OFF	OFF	常亮
	18-33%	OFF	OFF	OFF	OFF	flash 2	ON	OFF	OFF	OFF	OFF	ON	ON
	34-50%	OFF	OFF	OFF	flash 2	ON	ON	OFF	OFF	OFF	ON	ON	ON
	51-66%	OFF	OFF	flash 2	ON	ON	ON	OFF	OFF	ON	ON	ON	ON
	67-83%	OFF	flash 2	ON	ON	ON	ON	OFF	ON	ON	ON	ON	ON
	84-100%	flash 2	ON	ON	ON	ON	ON	ON	ON	ON	ON	ON	ON
Running light●				ON						flash(flash 3)			

LED Flashing Instructions

Flash way	Bright	NO
Flash 1	0.25S	3.75S
Flash 2	0.5S	0.5S
Flash 3	0.5S	1.5S

Note: The LED indicator light alarm can be enabled or disabled through the upper computer, and it is enabled by default at the factory.

8 Sleep and wake-up

8.1 Sleep

When any of the following conditions are met, the system enters low-power mode:

- 1) The single or overall over discharge protection has not been released within 30 seconds.
- 2) Press the button (3-6S) and release it.
- 3) The minimum cell voltage is lower than the sleep voltage, and the duration reaches the sleep delay time (while meeting the requirements of no communication, no protection, no balance, and no current).
- 4) Standby time exceeds 24 hours (no communication, no charging and discharging, no mains power).
- 5) Force shutdown through the upper computer software.
Before entering sleep mode, it is necessary to ensure that the input terminal is not connected to external voltage, otherwise it will not be able to enter low-power mode.

8.2 Awakening

When the system is in low-power mode and meets any of the following conditions, the system will exit low-power mode and enter normal operation mode:

- 1) Connect the charger, and the output voltage of the charger should be greater than 48V.
- 2) Press the button (3-6S) and release it.
- 3) RS232 activation is available.

9.Product Life

The design life of this product is 10-15 years.

10.Transportation

During transportation, please keep the battery from acutely vibration, impacting, over-exposure to the sun and drenching.

11.Storage

11.1 Storage environment requirement

Under temperature of 25 ± 3 . C and relative humidity of 45~85%.

11.2 Storage term

Lithium batteries must be recharged every three months and require a full charge and discharge cycle every six months.

12.Cautions

- * The installation and debugging should be operated by professional electric personnel.
- * Please do not stick your hands or other objects deep into the interior of the product.
- * Please do not open the product without a professional around.
- * Please do not mechanically damage the battery module of the energy storage cabinet (perforation, deformation, peeling, etc.).
- * Please use dry powder extinguisher as extinguishing agent.
- * Please do not let the storage cabinet battery module contact abnormal metals or conductors.
- * If the battery is short-circuited, contact the professional electrical personnel or battery manufacturer to check and remove the short-circuit protection before use.
- * Please do not expose the energy storage cabinet to flammable or hazardous chemicals or vapors.

13 Transportation

- 1) Customized wooden and cardboard packaging and delivery. During loading, unloading, and transportation, violent vibrations and significant external impacts must be avoided, and rolling, inversion, squeezing, and stacking too high are prohibited.
- 2) During transportation, rain should be avoided.
- 3) Before transportation, ensure that the battery or battery pack has been disconnected from the load on the charging device and there is no charging or discharging behavior of any kind.
- 4) Before transportation, the high and low voltage wiring harnesses should be fixed and protected to avoid damage to the harnesses or even short circuits caused by wire harness pulling during transportation.
- 5) If there is damage such as falling or water ingress during transportation, it should be placed separately and inspected by professionals.

14 Warranty repairs / replacements

Your battery is covered by warranty from the date of retail purchase for defective materials or workmanship.

Except for this limited warranty, we make no warranties and expressly exclude any implied warranties, including any warranties for consequential damages. This limited warranty is non transferable.

The seller guarantees that if used in accordance with all applicable instructions, this product will not have any original defects in materials and workmanship during the warranty period. If any malfunction occurs during the warranty period, the seller will decide to repair or replace the product based on the situation of the malfunction.

Limited Warranty

Save proof of purchase, such as a dated receipt. The warranty period of this device is extended to the original purchaser or user and may cover material and process defects. For malfunctions caused by material or process defects within six months from the date of purchase, we will make our own decision to repair or replace the equipment after inspection.

If any of the following situations occur, this warranty is invalid, but not limited to:

Not following the instructions in the user manual.

- Accidental or unreasonable use, misuse or improper handling, overcharging or loading, or normal wear and tear.

Extend storage time without the need for unauthorized personnel to charge, repair, or modify.

This warranty replaces all other express warranties. Apexium shall not be liable for indirect or consequential damages.

