

# User Manual

## C&I BESS with PV and GEN Port

Model: IYP-215KWH-100KH3M-HP1

IYP-241KWH-100KH3M-HP1



**Docan Technology(Shenzhen) Co.,Ltd.**

Tel: +86 13924590500

Email:info@apexiummall.com

Website:www.apexiummall.com

Address:Room401,Buildng 1 Longhua Street (1980 Science And Culture Industrial Park),Shenzhen, Guangdong, China

# Preface

## Overview

This document mainly describes how to install, connect, commission, and troubleshoot the energy storage system (hereinafter referred to as the "energy storage system").

Please read this manual carefully to get familiar with the safety instructions and functions, and features of the energy storage system before installing and using the energy storage system.

## Revision History

Date	Version	Note
2023.11.13	1.0	Original release
2024.07.18	2.0	
2025.02.05	3.1	

## Symbol Conventions



Indicates a situation with a high potential risk that could lead to death or serious injury if not avoided



Indicates a situation with a medium potential risk that could lead to death or serious injury if not avoided



Indicates a situation with a low potential risk that could lead to death or serious injury if not avoided



This is used to convey device or environment safety warning information.



This is used to highlight important/key information, best practices, and tips.

## Terminology

BESS: Battery Energy Storage System

ESS: Energy Storage System

C&I: Commercial and Industrial

PCS: Power Conversion System

BMS: Battery Management System

EMS: Energy Management System

BCU: Battery Control Unit

BMU: Battery Management Unit

SOC: State of Charge

SOH: State of Health

SOP: State of Power

SOE: State of Energy

FPS: Fire Protection System

FPM: Fire Protection Module

MPPT: Maximum Power Point Tracking

STS: Static Transfer Switch

ATS: Automatic Transfer Switch

A/C: Air-conditioner

FPS: Fire Protection System

APS: Auxiliary Power System

DG: Diesel Generator

PV: Photovoltaic

UPS: Uninterrupted Power Supply

PPE: Personal Protective Equipment

# Contents

<b>Preface .....</b>	<b>i</b>
<b>1 Safety Precautions .....</b>	<b>1</b>
1.1 General Safety Requirements .....	1
1.2 Personnel Requirements .....	5
1.3 Storage and Installation Environment Requirements .....	6
1.4 Unloading and Transport Requirements .....	10
1.5 Electrical Safety .....	11
1.6 Mechanical Safety .....	13
1.7 Battery Safety .....	17
1.8 Maintenance and Replacement .....	23
1.9 Emergency Plan .....	24
<b>2 About Product .....</b>	<b>26</b>
2.1 Model Description .....	26
2.2 Functions and Features .....	26
2.3 Appearance .....	28
2.4 Parts .....	29
2.4.1 LiFePO4 Battery System .....	32
2.4.2 PCS System .....	37
2.4.3 MPPT System .....	39
2.4.4 STS System .....	41
2.4.5 Air-conditioner System .....	43
2.4.6 Fire Protection System .....	45
2.4.7 Environment Control System .....	48
2.5 Operating Principle .....	49
2.5.1 Circuit Block Diagram .....	49
2.5.2 Equipment States .....	49
2.6 Typical Applications .....	50
<b>3 Site Requirements .....</b>	<b>52</b>
3.1 Site Selection Requirements .....	52
3.2 Forklift Requirements .....	54
3.3 Lifting Requirements .....	54
<b>4 Installation .....</b>	<b>56</b>
4.1 Preparations before Installation .....	56
4.1.2 Checklist before Installation .....	60
4.2 Installing Energy Storage System and Cables .....	60
<b>5 Power On .....</b>	<b>71</b>
5.1 Checklist before Power On .....	71

---

5.1.1 Routine Check .....	71
5.1.2 Checking the Installation of the Energy Storage System .....	72
5.1.3 Checking the PCS .....	73
5.2 Power-On Procedure .....	74
<b>6 Power-on Commissioning .....</b>	<b>76</b>
6.1 Getting Ready and Accessing On-line .....	76
6.2 Boot Wizard .....	76
6.3 Communication Interface Configuration .....	80
<b>7 Power Off .....</b>	<b>82</b>
7.1 Shutdown Command .....	82
7.2 Power-off Procedure .....	83
<b>8 Technical Specifications .....</b>	<b>85</b>
<b>9 Maintenance .....</b>	<b>87</b>
9.1 Explanation of Terms .....	87
9.2 Operating Instructions for Normal Operating System .....	87
9.3 Operating Instructions for Intermittent Operating System .....	87
9.4 Operating Instructions for Long-time Unused System .....	87
9.5 Function of Battery HV DC Breaker .....	88
9.6 Operating Method of Battery Maintenance .....	88
9.7 Maintenance Requirements for A/C System .....	89
<b>A Crimping OT/DT Terminals .....</b>	<b>91</b>
<b>B How to Repair Paint .....</b>	<b>94</b>
<b>C How to Recycle Used Batteries .....</b>	<b>99</b>
<b>D Contact Information .....</b>	<b>100</b>
<b>F Layout Drawing .....</b>	<b>101</b>
<b>Appendix 1 .....</b>	<b>103</b>

---

# 1 Safety Precautions

## 1.1 General Safety Requirements

### Statements

Please read this manual and follow the symbols on the device and all safety precautions in this manual before installing, operating, and maintaining the system.

The "Notice", "Caution", "Warning" and "Danger" in this manual do not represent all the safety precautions users should follow but only serve as a supplement to all the safety precautions. The Company does not assume any liability for damage or loss due to violation of general safety requirements or safety standards for the design, production and use of the system.

The system must be used in an environment that meets the design specifications. Otherwise, the system may be faulty. The resulting malfunction, component damage, personal injury, and property losses are not covered by the warranty.

Comply with local laws and regulations, and codes when installing, operating, and maintaining the system. The safety precautions in this manual only serve as supplements to local laws and regulations and codes. The Company shall not be liable in any of the following situations:

- The system is installed and operated in an environment that does not meet requirements in applicable international, national, and regional standards.
- The system is not operated under the conditions of use described in this manual.
- The product is disassembled or modified, or the software code is modified without authorization.
- The system is not operated according to instructions for use and safety precautions in the manual.
- Equipment damage caused by abnormal natural environment (force majeure, such as earthquake, fire, storm, flood, debris flow, etc.).
- Damage caused by customer's failure to comply with shipping and installation requirements.
- Damage caused by improper storage conditions.

- Hardware damage or data corruption caused by customer's negligence, incorrect operation, or intentional damage.
- System damage caused by third parties or customers, including damage caused by improper relocation and installation of the system, as well as damage caused by improper adjustment, change or removal of identification marks.
- Defects, malfunctions or damages caused by acts, events, omissions or accidents beyond the reasonable control of the Seller, including power outage, electrical failure, theft, war, riot, civil unrest, terrorism, and intentional or malicious damage.

## General Requirements

---



High voltage exists in the system. Improper operations may result in electric shock or fire, leading to death, serious personal injury, or property damage.

Please:

- Follow the operation procedure and safety precautions provided in this manual and other related documents.
- Follow the warning signs, warnings and protective measures indicated on the system.
- Follow the instructions provided in this manual, use the correct tools, and know how to correctly use these tools.
- Follow the safety regulations of the power plant, such as operation ticket and work ticket system.
- Do not approach the system except for system operators. Erect a temporary warning sign or fence to isolate the operation area.
- The warning sign, warning information, and protective measures must be legible. Do not alter, damage or cover the content, and replace if necessary.
- Do not perform installation, connection, maintenance, and replacement operations with power on.
- Do not clean the electrical components inside the system with water.
- Check the system for damage, such as holes, dents, or other signs of possible internal damage.
- Check that the pre-installed cables are securely connected.
- Check that the components inside the system are not displaced. Do not modify the structure or installation sequence without authorization.
- Do not power up the system when the system is not fully installed or confirmed by a professional.
- Measure the voltage at the contact before touching any conductor surface or terminal and ensure that the PE cable of the system or component to be repaired is reliably grounded and that there is no risk of electric shock.
- Press the emergency stop button and notify the site manager when any liquid dampens the system.
- Do not open the cabinet door when the system is operating.
- Wear arc protection clothing in the initial power-up or when you operate the main circuit with power on.

 **Caution**

- Do not perform arc welding, drilling, or cutting operations on the system.

Such operations may damage the sealing property of the entire cabinet, degrade the electromagnetic shielding performance of the system, or damage internal components and cables. Metal scraps generated during operations may enter the system, resulting in an electrical short circuit, malfunction or equipment damage.

- The housing is hot when the system is operating. Do not touch the housing. Otherwise, burn injury may occur.
- Immediately stop the system when a fault is detected that may cause personal injury or equipment damage, then report the event to the person in charge, and take effective protection measures.
- Evacuate from the scene immediately when the fire alarm is triggered.
- Close and lock the cabinet door when the equipment under operation and maintenance is left unattended temporarily.

 **Notice**

- Transport, transfer, install, connect, and maintain the system in strict accordance with the laws, regulations, and related standards of your country or region.
- User-supplied materials and tools required for operation shall meet the laws, regulations, and related standards of your country or region.
- The system can be connected to the grid only when permitted by the electric power department of your country or region.
- Clean the water, snow, ice, or other debris, if any, on the cabinet top before opening the cabinet door for installation, operation or maintenance to prevent debris from falling into the cabinet.

---

 **Description**

- Do not perform reverse engineering, decompilation, disassembly, reprogramming, implantation, or other derived operations on the software. Never research the internal implementation of the device in any way, obtain the source code of the software, steal intellectual property rights, nor disclose the results of any software performance tests.
  - You are advised to prepare your own camera device and record the detailed information of installation, operation, and maintenance.
- 

## 1.2 Personnel Requirements

- Only qualified personnel can operate the equipment, including transportation, transfer, installation, cable connection, and maintenance. Wear personal protective equipment that meets local safety protection requirements while operating the equipment.
- Operators must receive the relevant training and pass the examinations of the Company and have professional knowledge of the energy storage system.

 **Description**

For qualification requirements, refer to your local laws and regulations and industrial standards.

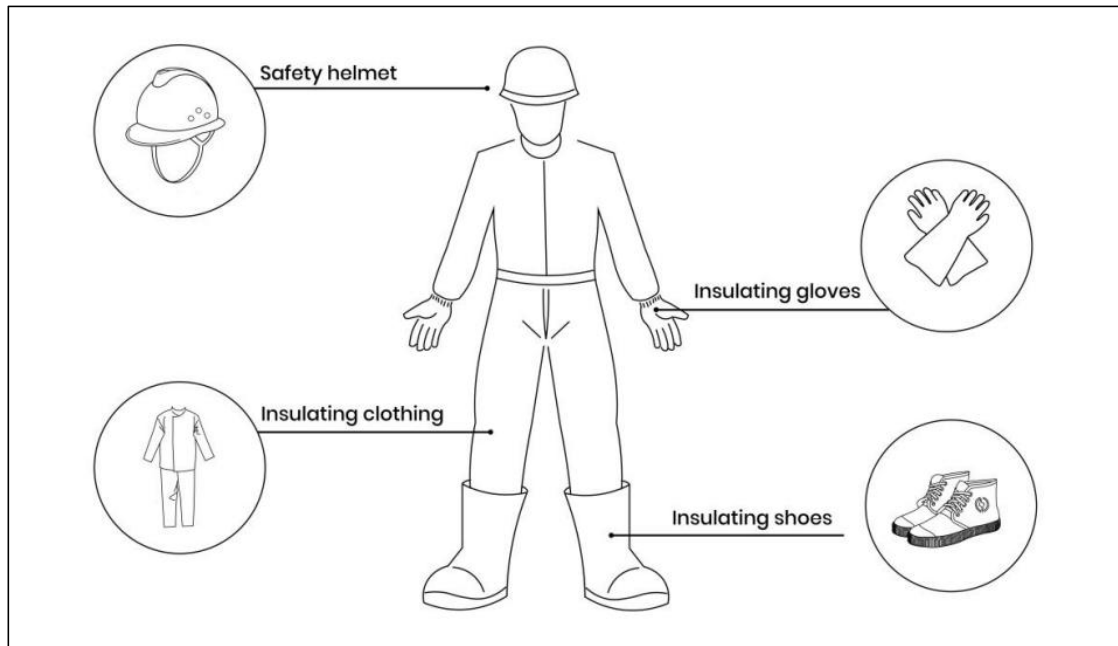

- Do not wear conductive objects such as watches, bracelets, rings, and necklaces during installation, operation, and maintenance to avoid burn injury due to electric shock.
- Transport, transfer, install, connect, and maintain the system in strict accordance with the laws, regulations, and related standards of your country or region.
- Keep familiar with the compositions and working principles of the energy storage system and operate the equipment according to the User Manual.

## 1.3 Storage and Installation Environment Requirements

### General Requirements

#### Description

- Keep certificates demonstrating compliance with product storage requirements, for example, temperature and humidity log data, storage environment photos, and inspection reports.
- Do not store the energy storage system for a prolonged period of time. Long-term storage of

---

a lithium battery will result in capacity loss. A lithium battery will generally be subject to irreversible capacity loss of 3% to 10% when it is stored at the recommended storage temperature for more than 12 months.

- Store the product in a clean and dry place that is free of dust and water vapor erosion. Avoid rain or ground water erosion.
- The ambient air must not contain corrosive or flammable gases.
- Do not tilt the product or store it upside-down.
- The devices, except for lithium battery packs, stored for two years or more, must be inspected and tested by professionals before being put into use.

## **Storage Requirements of Energy Storage System**

- Do not stack up.
- Ensure that the storage area is level (long-term or temporary).
- Keep the cabinet door tightly closed.
- Storage temperature: -30°C to +50°C, humidity: 5%RH to 95%RH.
- The energy storage system contains a lithium battery pack. Avoid direct sunlight or rain, and keep the environment dry, well-ventilated, and clean. There is no large amount of infrared radiation, organic solvents, or corrosive gases. Keep away from the ignition source.
- The lithium battery pack must not be stored and transported for more than five months in total (calculated from the date of delivery). Beyond this timelimit, the lithium battery pack must be recharged to 30% SOC and then subject to SOC calibration. Otherwise, the battery performance may be degraded and the service life may be reduced.
- The warehouse keeper should make monthly statistics on the storage capacity of energy storage systems, regularly inform the planning sequence of the inventory of energy storage systems, and recharge the energy storage systems that are stored for an extended period of time.
- The FIFO principle must be strictly followed for the delivery of energy storage systems.

## Installation Environment Requirements

For site selection, refer to [3.1 Site Selection Requirements](#). The following installation requirements must be met:

- Energy storage systems should be installed and arranged according to fire-break distance or fire partition wall requirements in your local standards, including but not limited to GB51048-2014 Design code for electrochemical energy storage station and NFPA855 Standard for the installation of stationary energy storage systems.
- Never place the equipment in an environment with flammable or explosive gas or smoke, nor perform any operations in such an environment.
- Do not install, use, or operate outdoor equipment and cables (including but not limited to transporting equipment, operating equipment and cables, plugging and unplugging signal cables connected to outdoor ports, working at heights, or installing outdoors) in severe weather conditions such as lightning, rain, snow, and force 6 wind or higher.
- Protective measures such as fences and enclosures must be set up for energy storage systems, and safety warning signs must be erected for isolation to prevent unauthorized personnel from accessing the equipment when it is operating. Otherwise, personal injury or property damage may occur.
- Do not block the vents and cooling system when the equipment is operating to prevent fire hazards due to high temperatures.
- The equipment should be installed in an area away from liquid, and should not be installed under water pipes and air outlets that are prone to condensation. Do not install the equipment under the air conditioner vent, air vent, or cable leading-out window of the equipment room to prevent liquid from entering the equipment and causing malfunction or short circuit.
- Keep the installation location away from an ignition source. Keep the equipment away from flammable or explosive materials.
- If the equipment is installed in a vegetated area, in addition to routine weeding, the foundation beneath the equipment needs to be hardened to prevent weeds.

## **Requirements for Working at Heights**

- Take protective measures, wear PPEs including a safety helmet, safety belt, and waist strap, and tie the safety belt and waist strap to a rigid structure. Do not hang to an unstable moving object or metal with sharp edges to prevent the hook from slipping, leading to falling accidents.
- Define a restricted zone by setting a visible sign reading "No Entry" when working at heights.
- Do not stack scaffolding, springboards, and other foreign matters on the ground underneath the work platform. Personnel on the ground should not stay or pass through underneath the work platform.
- Do not throw objects at heights to the ground or from the ground to the height. Instead, use ropes, hanging baskets, elevated vehicles, or cranes to transport objects.
- Inspect the scaffolding, springboard, and work platform for safety to guarantee that the structure is rigid and the scaffolding is not overloaded.
- Do not work at heights on rainy days or other dangerous situations. When this happens, always ask the safety director and engineers to re- inspect various operation equipment for safety before proceeding with working at heights.
- Erect fences and signs at edges and openings when working at heights to prevent missing steps.
- Carry the operating apparatuses and tools to prevent the tools from falling.
- The person in charge of the site and the safety officer should immediately point out operations against regulations, if any and hold them accountable for correction before proceeding with operations.

## 1.4 Unloading and Transport Requirements

---

### Danger

Maintain and unload the lithium battery pack in accordance with your local laws and regulations and industrial standards. Improper unloading may result in damage or short circuit, leading to electrolyte leakage, breakage, explosion or fire hazard.

---

### Notice

This product has passed **UN38.3** (*UN38.3: Section 38.3 of the sixth Revised Edition of the Recommendations on the Transport of Dangerous Goods: Manual of Tests and Criteria*) and **SN/T0370.2-2009** *Rules for the inspection of packaging for export dangerous goods - Part 2: Performance test*, and this product belongs to Class 9 dangerous goods.

---

### Shipping conditions:

- Check the energy storage system before shipping that the cabinet is intact, the cabinet door is closed and tightened, no foreign body is extended from the cabinet, and no smoke or smell of scorching is detected.

### Description

Handle the equipment with due care during loading and unloading and transport and take protective measures against moisture With environmental limitations (such as temperature, transport, and storage), technical specifications shall be subject to the date of delivery.

### Transport requirements:

- The energy storage system or battery shall not be transported by railway or air.
- For sea transport requirements, refer to International Maritime Dangerous Goods Code (IMDG CODE).
- For land transport requirements, refer to ADR or JT T617.
- Meet the regulatory requirements of the transport regulatory authorities of the departure

country, the transit country, and the destination country.

- Comply with the international rules for the transport of dangerous goods and the regulatory requirements of the respective national transport regulatory authorities.
- The transport process is fully monitored.
- The vehicle used for land transport shall be capable of carrying a single energy storage system weighing about 2700 kg.
- Speed limit for land transport: 80 km/h on a level road and 60 km/h on a rough road. In case of conflict, the local traffic regulations shall prevail.
- Do not stack up at ports or during sea transport. Avoid the following conditions during transport:
  - Falling into water.
  - Fall or mechanical impact.
  - Upside-down or tipping over.

#### Description

If any one of the preceding situations occurs, initiate an emergency plan as described in Section 1.9.

## 1.5 Electrical Safety

### Cabling Requirements

- Do not push cables directly down from the transport vehicle.
- Do not route cables through air inlet and outlet of the equipment.
- Tie cables of same type together. Route cables of different types at least 30mm apart. Do not twine or cross cables each other.
- Always seal cable holes with sealing mud upon completion of cabling or it is left unattended for a short period of time to avoid tiny animals.
- The insulation layer may be aged or damaged when cables are used at high temperatures. The cables should be at least 30mm away from the heating device or heat source.

- Select cables that comply with local laws and regulations.
- The edges of cable ducts and holes must be free of burr and well protected.
- Protect cable ducts and holes against damage due to sharp edges and burrs.
- Cables used in the energy storage system must be securely connected, properly insulated, and of appropriate specifications.
- After cables are connected, fix them with cable supports and cable clips. Ensure that cables in the backfilling area are tightly fitting to the ground to prevent deformation or damage caused by stress on cables during backfilling.
- At extreme low temperature, violent shock or vibration may result in brittle cracking of plastic cable sheath. The following requirements should be met to guarantee construction safety:
  - ✧ All cables should be routed and installed under temperature above 0°C. Handle cables with due care, especially in a low- temperature environment.
  - ✧ If cables are stored at temperature lower than 0°C, store cables at room temperature for at least 24 hours before routing.

## **Grounding Requirements**

- Do not damage the grounding conductor.
- Do not operate the equipment without a ground conductor installed.
- First install the PE conductor for the equipment to be grounded. The PE conductor shall be removed in the last step when the equipment is to be removed.
- The primary grounding body shall be permanently connected to the protective grounding net. Check the electrical connections before the operation to ensure that the equipment is reliably grounded.
- The ground impedance shall meet GB50054 and local electrical standards.

## **AC and DC Control Requirements**

- Cut off the power switch before installing and removing the power cord.
- Check that the power cord is correctly identified before connecting.

- 
- If there are multiple power inputs, cut off all power inputs and wait until the equipment is fully powered off before operating the equipment.

## Operation, Maintenance, and Repair Safety Requirements

1. Cut off the respective circuit protection switch before connecting or removing a cable.
2. Erect a warning sign reading "Don't Turn On" at disconnected switches.
3. Use an electroscope at the corresponding voltage rating to check for power and ensure that the equipment has been completely powered off.
4. If there are charged bodies nearby, cover or wrap them with an insulating board or tape.
5. Connect the circuit to be repaired to the grounding circuit with a grounding wire reliably before operation, maintenance, and repair.

---

### Notice

- Check that cables are correctly identified before connecting.
- If there are multiple power inputs, cut off all power inputs and wait until the equipment is fully powered off before operating the equipment.

- 
6. Upon completion of maintenance, remove the grounding wire between the circuit to be repaired and the grounding circuit.

## 1.6 Mechanical Safety

### Lifting Safety

---

#### Caution

- This equipment shall be lifted with two reliable ropes, which one can lift more than 3 tons.
- The rope one must pass through the hole A1 and B1, and the rope two must pass

through the hole C1 and D1.

- The rope one and rope two must be fixed firmly on the hole A2, B2, C2, D2, as shown in the following figure.
- 

- The foundation where lifting operation will be performed shall be solid enough to load the crane.
- Before lifting, ensure that the lifting appliances are firmly fixed to a rigid structure or wall that meets the load-bearing requirements.
- Do not drag wire ropes and slings during lifting operations. Avoid impact from hard objects.
- Do not walk under the crane jib or lift load.
- Erect a temporary warning sign or fence to isolate the lifting area.
- Keep the hook at least 1 m above the cabinet top.
- The cabinet is tilted not more than 10°.

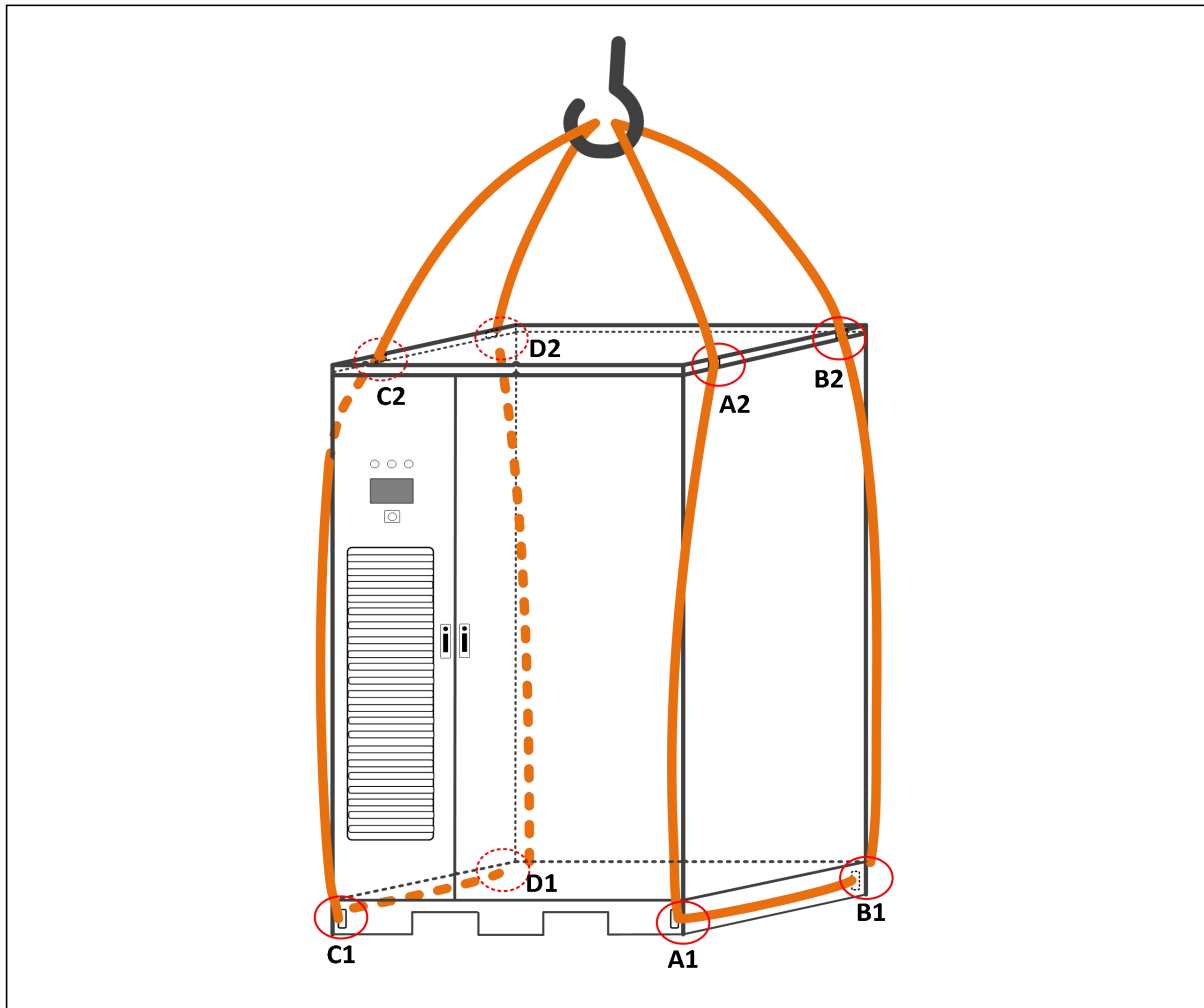

## Ladder Safety

- Do not use a straight ladder.
- Please check that the ladder is in good condition and meets load capacity requirements before use.
- Use a wooden ladder or fiberglass ladder to ascend a height.
- A platform ladder with guard is preferred for ascending a height. All four feet must be fixed and the ladder is held securely by someone when an operator is working at heights.
- If a herringbone ladder is used, the rope must be secured and the ladder is held securely by someone when an operator is working at heights.

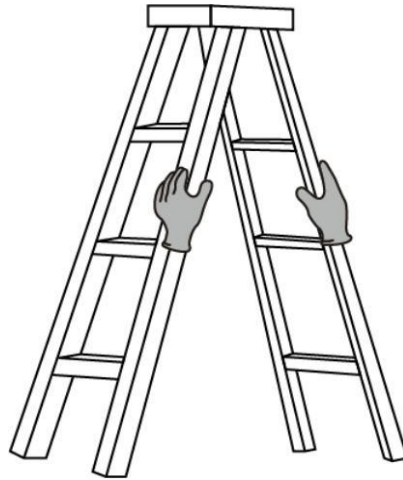

- Please pay attention to the following rules to reduce the risk and guarantee safety when climbing the ladder.
  - Keep your body in a stable posture.
  - The maximum standing height of the operator's feet should not exceed the fourth step of the ladder from the top down.
  - Make sure your center of body weight does not deviate from the edge of the ladder assembly.

## Drilling Safety Outside Equipment Body

- Before drilling, select a proper position to ensure that no short circuit exists.
- Always wear PPEs including goggles and protective gloves during drilling operation.
- Cover the equipment during drilling operations to prevent debris from falling into the equipment. Clean up debris immediately after drilling.

## Handling Safety

- Work together with the number of workers as recommended in the drawing to get prepared for moving heavy loads.

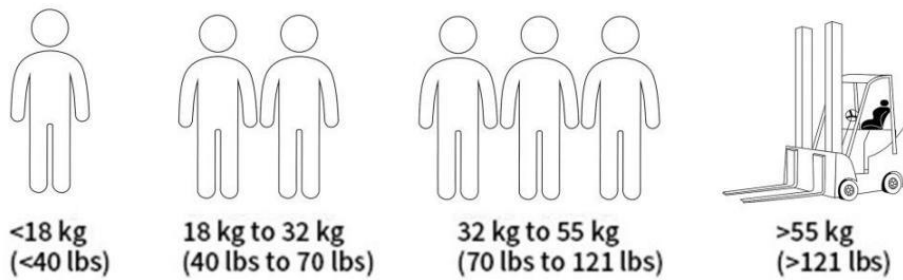

- Always wear PPEs including protective gloves and anti-smashing shoes when handling the equipment with hands.
- Do not scratch the surface of the equipment, damage components, or damage cables when handling the equipment.
- A forklift, if used, shall hold the equipment in the middle to prevent tipping over. Before moving, please fasten the equipment to the forklift with a rope and when moving, assign a person to care for the movement.
- Move the equipment with due care to avoid impact or falling.

## 1.7 Battery Safety

### Statements

The Company shall not be responsible for damages caused by the battery provided by the Company due to the following reasons:

- Extended storage, capacity loss or irreversible battery damage due to delayed charging on the customer side.
- Battery damage caused by delayed acceptance on the customer side.
- Degraded battery performance due to incorrect system operation management policy on the customer side.
- Unauthorized change to battery pack usage scenario on the customer or third party side without prior notice to the Company, for example, connecting an extra load to the battery pack or mixing the battery pack provided by the Company with that provided by other

---

manufacturers, including but not limited to mixing battery packs from different manufacturers or of different rated capacities.

- Direct damage to the battery pack because the equipment operating environment or external power supply parameters fail to meet environment requirements for normal operation, including too high or low operating temperature of the battery pack.
- Frequent over discharge due to improper maintenance, unauthorized on-site capacity expansion, or failure to fully charge the battery pack for a prolonged period of time on the customer side.
- Failure to correctly maintain the battery pack according to the User Manual, including but not limited to, checking whether the cooling system is in good condition, the high voltage wiring harness is loose or broken, and the screws fixing the structural parts are loose.
- The lithium battery pack is stolen.
- Lithium battery pack beyond the warranty period.

## General Requirements

---



- Do not expose the lithium battery pack to high temperature or heat source, such as direct sunlight, ignition source, transformer, heater, etc. Too high temperature of the lithium battery pack may lead to fire or explosion hazard.
- Do not disassemble, modify, or destroy the lithium battery pack, for example, inserting a foreign body or immersing it in water or other liquid, to avoid leakage, overheating, fire or explosion hazard of the battery pack.
- The lithium-ion battery energy storage system is at high risk of fire hazard. Take into full account the following safety risks before operating the battery:
  - The electrolyte in the lithium battery pack is flammable, toxic and volatile.
  - The thermal runaway of the lithium battery pack will produce flammable gases, as well as harmful gases such as CO and HF.
  - There is a risk of deflagration and explosion caused by accumulated

---

combustible gas after the thermal runaway of the lithium battery pack.

---

- If the lithium battery pack is flooded unexpectedly, stop the installation and then transport it to the safety isolation point, and apply for replacement parts in time.
- The storage area shall avoid direct sunlight or rain. Keep the environment dry, well-ventilated, and clean. There is no large amount of infrared radiation, organic solvents, or corrosive gases.
- The lithium battery packs shall be stored with their original packages in a separate warehouse. Do not store them together with other materials. Do not store them outdoors. Do not stack lithium battery packs up too high. The site must be equipped with the necessary firefighting facilities, such as a fire sandbox, fire extinguisher, etc.
- The energy storage system shall be regularly checked for firefighting safety at least once a month.
- Do not remove the original package of the lithium battery pack under normal circumstances. Ask a specialist to recharge the lithium battery pack when necessary. Install the lithium battery pack into its original package after recharging.
- In outdoor scenes, you are advised to power up the lithium battery pack within 24 hours after it is unpacked. Otherwise, place the lithium battery pack indoors in a dry, non-corrosive gas environment.
- The lithium battery pack must be correctly placed according to the "Keep Upright" symbol or label on the package to avoid battery leakage due to upside-down for an extended period of time.
- The lithium battery pack should avoid impact.
- Handle the lithium battery pack according to orientation requirements. Do not place it upside down or tilt it.
- Please use the lithium battery pack within the temperature range specified in this Manual. Do not charge the lithium battery pack when the ambient temperature is lower than the operating temperature lower limit. Otherwise, charging at low temperatures will result in condensation, leading to a short circuit of the lithium battery pack.
- Please dispose of scrapped lithium battery packs according to local laws and regulations. Do

not dispose of lithium battery packs as household waste. Improper disposal of lithium battery packs may result in environmental pollution.

- Do not use damaged lithium battery packs (dented housing or other damage). Damaged lithium battery packs may release flammable gases. Do not store damaged lithium battery packs near good ones.
- Store damaged lithium battery packs in a place free of flammable materials and erect a "No Entry" sign.
- Check damaged lithium battery packs for signs of smoke, fire hazard, electrolyte leakage or heating during storage.

## Recharging Requirements

- Recharge stored lithium battery packs at least every 5 months. Otherwise, the battery performance may be degraded and the service life may be reduced.
- You can get the time of production of lithium battery packs through their SN or consulting with the service engineer of the Company for evaluation.

## Installation Requirements of Lithium Battery packs



Check that the lithium battery pack is in good condition before installation. Any one of the following symptoms is deemed as a malfunction of the lithium battery pack:

- The housing of the lithium battery pack is obviously deformed or damaged.
- The total positive voltage or total negative voltage of the lithium battery pack is far below the specification range.
- Please use the lithium battery pack of the specified specification. A non-genuine lithium battery pack can be easily damaged.
- Please check whether the package is in good condition before installing the lithium battery pack. Do not use the lithium battery pack with damaged package.
- Place the lithium battery pack at a level and solid surface.

- 
- Do not place installation tools or loads on the lithium battery pack during installation.
  - Pay attention to the polarity of the lithium battery pack during installation. Do not short-connect positive and negative poles.
  - Tighten the connection terminals with a torque wrench and regularly check that connection terminals are not loose.

## Short-circuit Protection

---



Short-circuit may produce transient current surge and release a large amount of energy that may lead to personal injury or property loss.

---

- Wrap the exposed cable terminals in the lithium battery pack with insulating tape during installation and maintenance.
- Prevent foreign bodies (such as conductive objects, screws, and liquid) from entering the lithium battery pack, causing short circuits.

## Hazard and Toxicity

---



- Hazard: A damaged lithium battery pack may cause heating or electrolyte leakage. The electrolyte is flammable, and if the electrolyte leaks, the lithium battery pack should be immediately kept away from the ignition source.
  - Toxicity: The steam produced by the combustion of the lithium battery pack may irritate the eyes, skin and throat.
-

---

## Exception Handling Measures

---



- When there is electrolyte leakage or abnormal odor, do not expose to the leaking liquid or gas. Stay away and contact a professional immediately. A professional shall wear PPEs including goggles, rubber gloves, gas mask, and protection suit to prevent the harm caused by electrolyte spillage.
  - The electrolyte is corrosive and exposure may cause skin irritation and chemical burns. The following measures should be taken if you expose to the electrolyte.
  - Inhalation: Evacuate from the contaminated area, move to fresh air immediately, and seek medical attention immediately.
  - Eye contact: Immediately flush eyes with plenty of fresh water for at least 15 minutes. Do not rub your eyes. Seek medical attention immediately.
  - Skin contact: Wash contact areas immediately with plenty of soapy water, and seek medical attention immediately.
  - Ingestion: Seek medical attention immediately.
- 

## When Lithium Battery pack Falls

- When the lithium battery pack falls (with or without packing materials), but the appearance is not significantly deformed or damaged, and there is no obvious odor, smoke, and fire, perform the following operations on the premise of guaranteeing safety:
  - Warehouse: Evacuate personnel, ask a professional to transport the lithium battery pack to an open and safe place with mechanical tools, and contact the service engineer of the Company. Rest the equipment for 1 hour and check that the temperature of the lithium battery pack is within the range of room temperature  $\pm 10^{\circ}\text{C}$  before proceeding.
  - Site: Evacuate personnel, shut down the energy storage system, ask a professional to transport the battery pack to an open and safe place with mechanical tools, and contact the service engineer of the Company. Rest the equipment for 1 hour before proceeding.

- If there is obvious odor, damage, smoke or fire when the lithium battery pack falls, immediately evacuate personnel, contact a professional, and call firemen. The professionals on-site shall use fire fighting facilities to extinguish the fire on the premise of guaranteeing safety.
- Stop using the lithium battery pack when it falls. Instead, contact the service engineer of the Company for evaluation.

## 1.8 Maintenance and Replacement

---



Ensure that the remaining components are secure before removing a component from the cabinet.

---

- Assign two or more persons on site to maintain the energy storage system.
- Cover charged parts nearby with insulating materials during maintenance.
- Do not open the cabinet door in rainy, snowy, thunder, dusty, or foggy weather.
- Do not touch the fan in operation with any objects (such as fingers, parts, screws, or tools) while the fan is running before the fan is powered off and stops.
- Do not power on the equipment before trouble is eliminated.
- When inspecting the system with power on, pay attention to the hazard sign on the equipment. Do not stand near the cabinet door.
- Wait at least 15 minutes after devices except for the lithium battery pack are powered off. Ensure that these devices are completely powered off before performing operations.
- Erect a warning sign reading "Don't Turn On" at disconnected switches during maintenance.
- When the power unit of the energy storage system is replaced or cables are changed, manually start wiring test and run topology identification to avoid malfunction.
- Lock the cabinet door immediately after maintenance and replacement, fix the safety rope, and keep the key safe.

## 1.9 Emergency Plan

When dangerous accidents occur on site, including but not limited to the following accidents, give priority to personal safety and, contact the service engineer of the Company.

### In Case of Fire

---



#### **Suggestions for on-site operation and maintenance personnel:**

1. In case of fire, evacuate personnel from the building or equipment area and press the fire alarm bell. Immediately call your fire emergency number to notify professional firemen, and provide them with relevant product information, including but not limited to the type of lithium battery packs, the capacity of the energy storage system, and the layout of lithium battery packs.
2. Do not enter the burning building or equipment area again under any circumstances, and do not open the cabinet door. Isolate and guard the scene and erect a sign reading "No Entry".
3. Call your fire emergency number and remotely power the system off on the premise of ensuring personal safety.
4. Provide on-site firemen with relevant product information, including but not limited to: the type of lithium battery packs, the capacity of the energy storage system, the layout of lithium battery packs, and the User Manual.
5. After the fire is extinguished by firemen, the professionals shall take measures in accordance with local laws and regulations. Do not open the cabinet door without authorization.

Maintenance after an incident: Contact the service engineer of the Company for evaluation.

#### **Suggestions for firemen:**

1. Have knowledge of product information provided by the operation and maintenance personnel, including but not limited to the type of lithium battery

packs, the capacity of the energy storage system, the layout of lithium battery packs, and the User Manual.

2. Do not open the cabinet door when the internal safety of the energy storage system cannot be guaranteed.

3. Please follow local firefighting regulations.

---

## 2 About Product

### 2.1 Model Description

Model description:



This document mainly describes the following model: **IYP-215KWH-100KH3M-HP1**

## 2.2 Functions and Features

### Functions

The IYP-215KWH-100KH3M-HP1 is highly integrated BESS(battery energy storage system). It is integrated Battery, BMS/PCS/EMS/STS/ATS, Air-conditioner and Fire Protection System, MPPT and Diesel Generator port.

So the BESS can connect the Grid, PV and Diesel generator. And it can run on hybrid mode(grid and off grid).

- **On-grid mode**

The AC side of the energy storage system is connected to the power grid and the DC side is connected to the battery pack and PV. The product can be applied in power expansion, photovoltaic power generation, energy storage, and charging power consumers, as well as peak-load shifting. The product can charge or discharge lithium batteries at constant voltage, current, and power according to the selected operation mode.

- **Off-grid mode**

When connected to the power grid, the energy storage system can output three-phase AC voltage with fixed frequency and RMS. When used with a transformer , the system continuously supplies power to the loads on the AC side. And the BESS system integrated STS and ATS, so it can seamlessly switch between on-grid mode and off-grid mode.

## **Features**

The energy storage system integrates the power supply and distribution system, monitoring system, MPPT, STS, ATS, environmental control system, and fire protection system, and features high safety and reliability, rapid deployment, low cost of ownership, high energy efficiency, and intelligent management.

- Racks are optimized individually and energy is managed at the rack level to avoid parallel loop of battery racks.
- Standard modules can be spliced as needed for easy maintenance and scaling up.
- Air-conditioner cooling, high energy density, low footprint, and highly consistent cell temperature
- Systems can be connected in parallel in hybrid mode.

### 2.3 Appearance

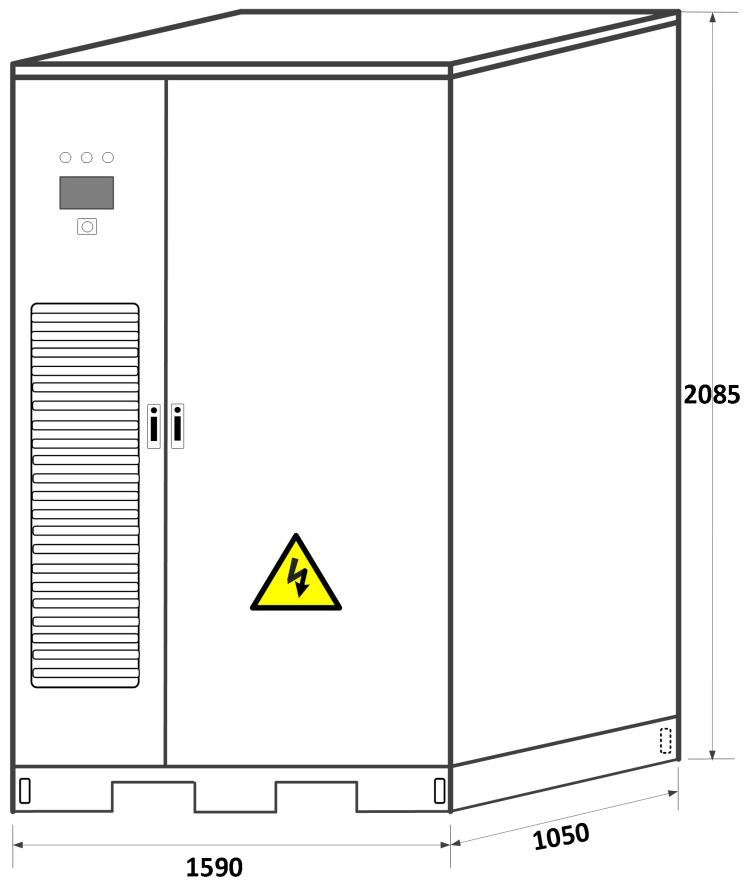

Figure 2-1 Appearance

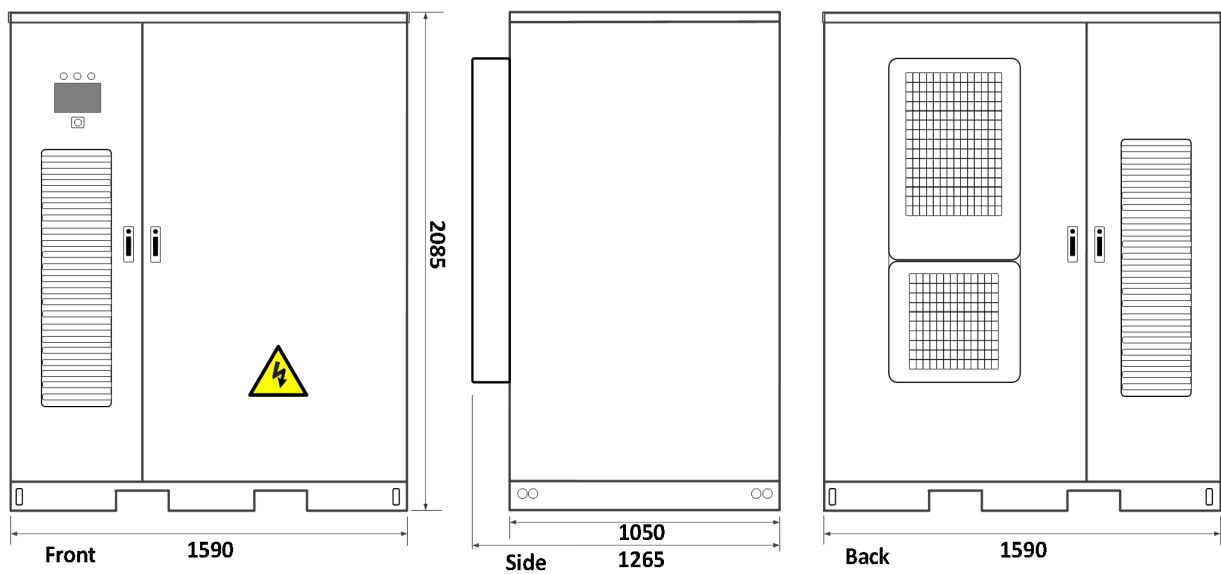

Figure 2-2 Dimensions

Description

For foundation requirements, refer to the description in the construction drawing, which is available from F part.

## 2.4 Parts

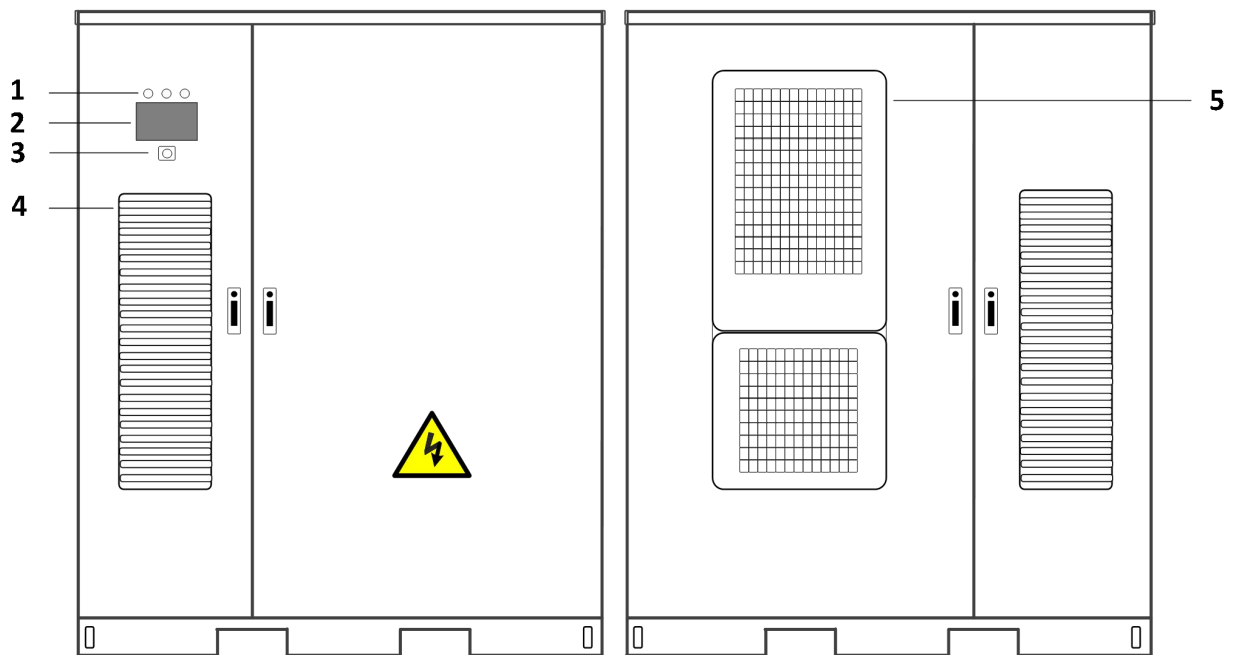
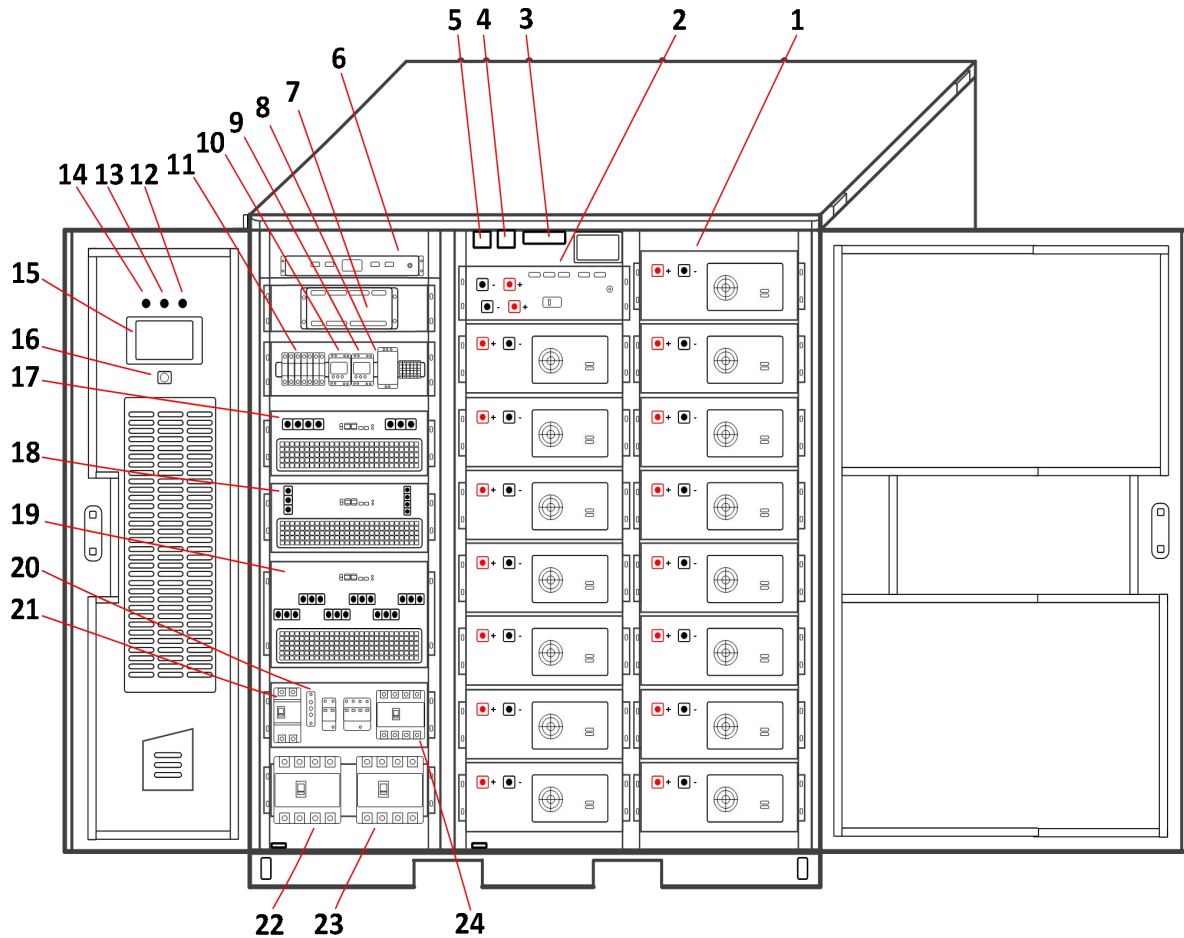

Figure 2-3 Parts (Door closed)

Table 2-1 Part configuration

SN	Name	Quantity	Description
1	Indicators	3	Power: Green. The indicator goes on when the auxiliary power supply is ON. Run: Green. The indicator goes on when the system work normally. Fault: Red. The indicator goes on when fault occurs.
2	Display Screen	1	System display and operation screen.

3	Emergency stop	1	You can press this button to stop the system immediately when the equipment malfunctions.
4	Air inlet	1	Air inlet of PCS/MPPT/STS etc.
5	A/C	1	Air-Conditioner for LiFePO4 battery cooling



**Figure 2-4** Parts (Door open)

**Table 2-2** Part configuration 2

SN	Modules	Quantity	Description
1	LiFePO4 battery pack	15	LiFePO4 battery pack with BMU (voltage and temperature monitor and communication), integrated FPM and FAN
2	HV box	1	LiFePO4 battery pack management box with BCU, integrated fuse, relay and breaker etc.

3	Fire protection module	1	Aerosol fire extinguishing. The system automatically starts the fire protection system in case of fire.
4	Smoke detector	1	Smoke detector sensor is used to prevent fire in advance
5	Temperature detector	1	Temperature detector sensor is used to prevent fire in advance
6	UPS	1	UPS, guaranteeing normal operation of the energy storage system upon power outage.
7	EMS	1	Local Energy Management System, used for energy management and communication
8	APS	1	AC Power to DC Power for EMS/BMS and control system
9	Meter1	1	Meter for grid
10	Meter2	1	Meter for Load
11	QF1~QF5	5	Circuit breaker bank
12	Power indicator	1	Green, The indicator goes on when the auxiliary power supply is ON.
13	Run indicator	1	Green, The indicator goes on when the system work normally.
14	Fault indicator	1	Red, The indicator goes on when fault occurs.
15	Display Screen	1	System display and operation screen.
16	Emergency stop	1	You can press this button to stop the system immediately when the equipment malfunctions.
17	MPPT	1	PV MPPT module
18	PCS	1	PCS module
19	STS	1	STS module for on-grid and off-grid switch
20	PV-	1	Connect to PV-
21	PV+ Breaker	1	Connect to PV+
22	Grid Breaker	1	Grid AC breaker
23	DG Breaker	1	Diesel Generator AC breaker
24	Load Breaker	1	Load AC breaker

### 2.4.1 LiFePO4 Battery and BMS System

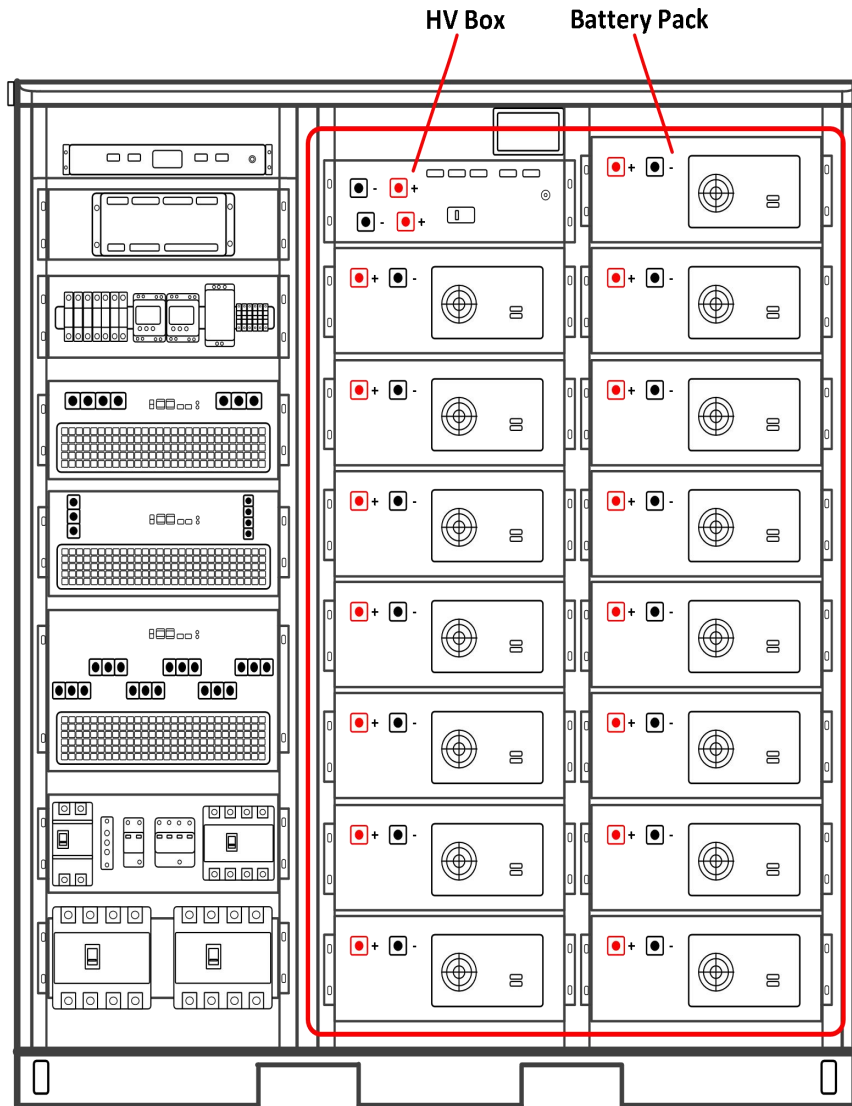

Figure 2-5 Location of the battery system

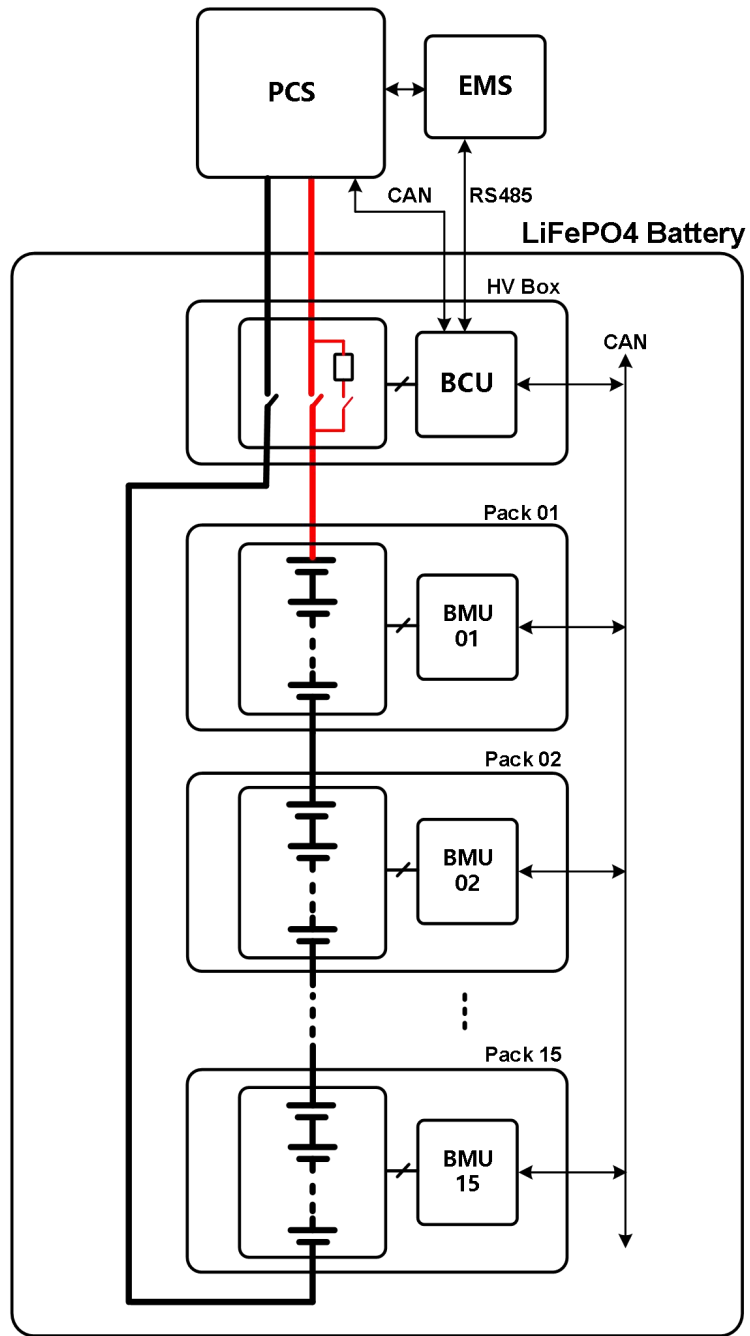
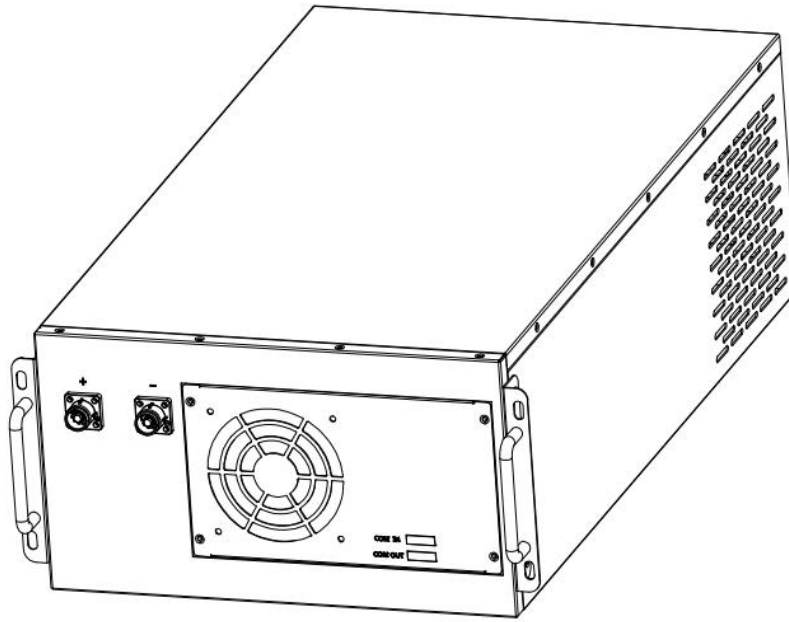

Figure 2-6 System topology

### 2.4.1.1 Battery Pack



**Figure 2-7** Appearance of battery pack

**Module description:**

A LiFePO4 battery pack contains 16 cells and BMU(Battery Management Unit). And the battery pack is 51.2V280Ah. BMU contains cell voltage and temperature monitor. All of the battery pack's information send to the BCU by BMU.

**Table 2-3** Technical parameters

NO.	Item	Specification	Notes
1	Battery type	LiFePO4 Battery	
2	Nominal voltage	51.2V	
3	Rated capacity	280Ah	Cell: 3.2V280Ah
4	Cell Number	16	1P16S
5	Standard charge current	100A	

6	Max. Charge current	200A	
7	Max. Discharge current	200A	
8	Communication	CAN	
9	Work temperature	Charge: 0~55℃ Discharge: -20~60℃	
10	Cooling mode	Forced air cooling	
11	Size	400*720*225mm	
12	Weight	105kg (about)	

### 2.4.1.2 HV Box

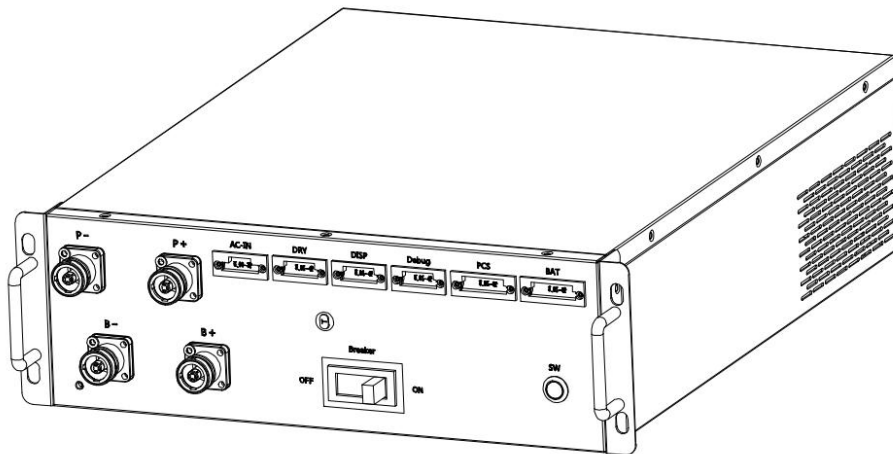

**Figure 2-8** Appearance of HV Box

#### Module description:

This module integrates BCU, DC fan, circuit breaker, fuse, HV relay and 24V power supply.

The main features include the followings:

- Power-off protection upon battery fault
- Under the management of BMS, the module can separately implement capacity calibration and SOC calibration as the basis for subsequent charge and discharge management
- The module collects BMU information through CAN and transmits this information to the PCS and EMS.

**Table 2-3** Technical parameters

Model	IYP-HVM2
Application scenario	Outdoors
DC rated voltage	DC 1000V
DC rated current	200A
Max.power of auxiliary power supply	50W
Rated voltage of auxiliary power supply	230V
Function	Over voltage protection, Under voltage protection, Over current protection, Over temperature protection, SOC, SOH, etc.
Communication	CAN/RS485
Size	442*500*133mm
Weight	30kg(about)

## 2.4.2 PCS System

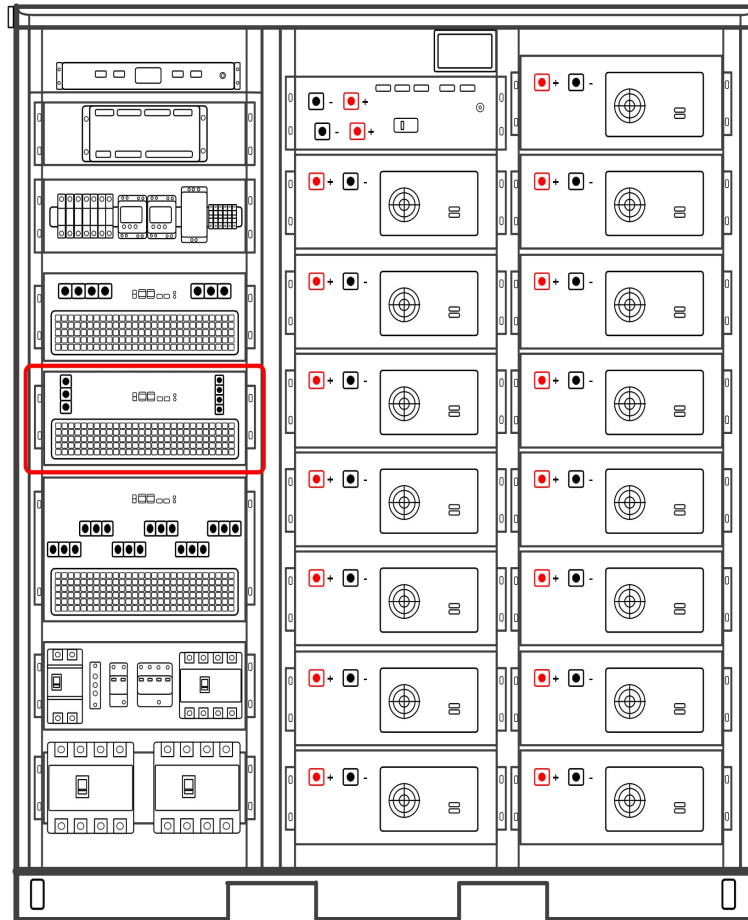

**Figure 2-9** Location of the PCS

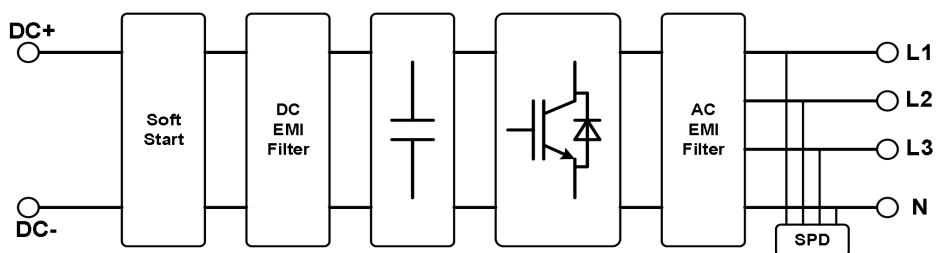
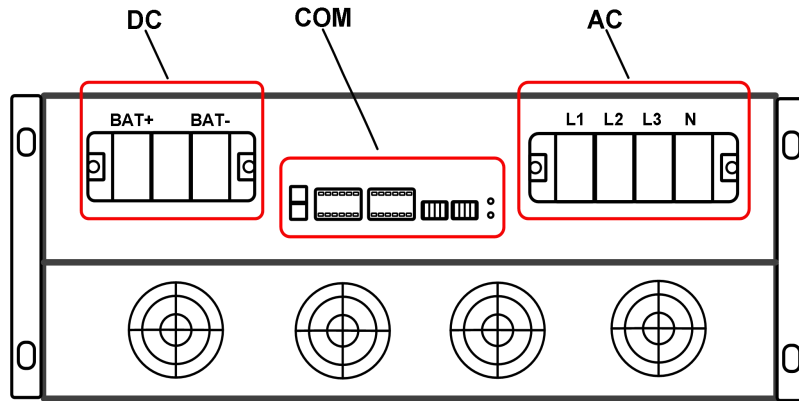

**Figure 2-10** Block diagram of PCS

### Module description:

The PCS system is mainly intended for electric energy conversion between power grid and battery, and monitors and manages the conversion process. The energy storage converter can

run in on-grid mode and off-grip mode.



**Figure 2-11** Appearance of PCS

**Table 2-4** Technical specification

Model	IYP-PCS100K
Rated power	100kW
Max.power	100kW
DC voltage range	600V~950V
Max. DC current	150A
Rated AC voltage	400Vac/230Vac
Rated frequency	50/60Hz
Max. AC current	145A
Overload capacity	Rated power 1.1 times about 10s Rated power 1.25 times about 30ms
Current distortion	<3%(rated power)
Unbalanced loading capacity	90%
Max. efficiency	98%
Size	440*720*200mm
Weight	55kg (about)

Isolation mode	Non-isolation
Ingress protection	IP21
Operating temperature	-25℃~+55℃(derating when the temperature is greater than 45℃)
Relative humidity	0~95%(without condensation)
Cooling method	Smart air cooling
Altitude	3000m(derating when the altitude is higher than 2000 m)
Communication	CAN/RS485

### 2.4.3 MPPT System

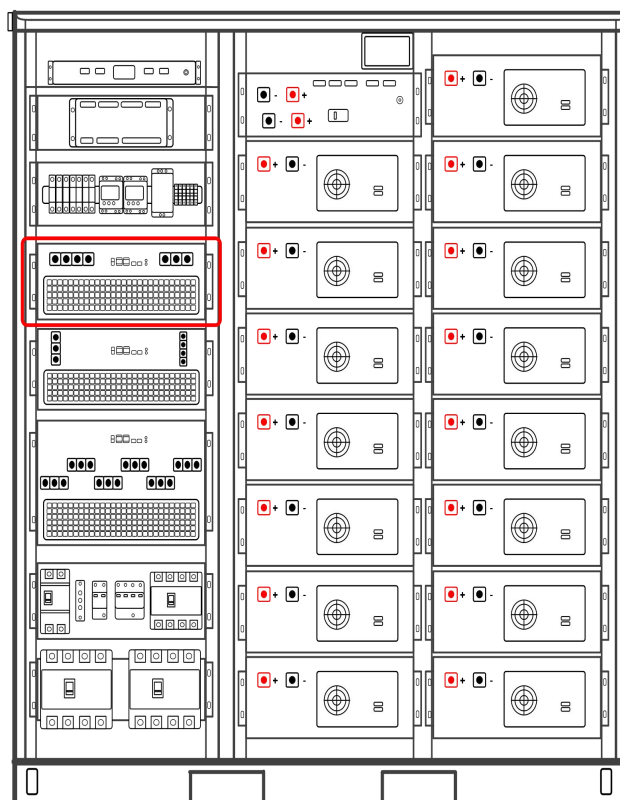

Figure 2-12 Appearance of MPPT

**Module description:**

The MPPT system is PV controller. It track the Maximum power of the PV all the time. It is a DC to DC system.

**Table 2-5** Technical specification

Model	IYP-MP120K
Rated power	120kW
Max. PV open voltage	950Vdc
MPPT voltage range	250~850Vdc
Max. PV current	200A
MPPT channel	1 or 4
Battery voltage range	550~900Vdc
Max. Battery current	180A
Max. efficiency	99%
Size	440*560*183mm
Weight	30kg (about)
Operating temperature	-25°C~+55°C (derating when the temperature is greater than 45°C)
Relative humidity	5~95%(without condensation)
Cooling method	Smart air cooling
Altitude	3000m(derating when the altitude is higher than 2000 m)
Communication	CAN/RS485

**Note:** PV open voltage must be lower than 950Vdc in the lowest temperature.

### 2.4.4 STS System

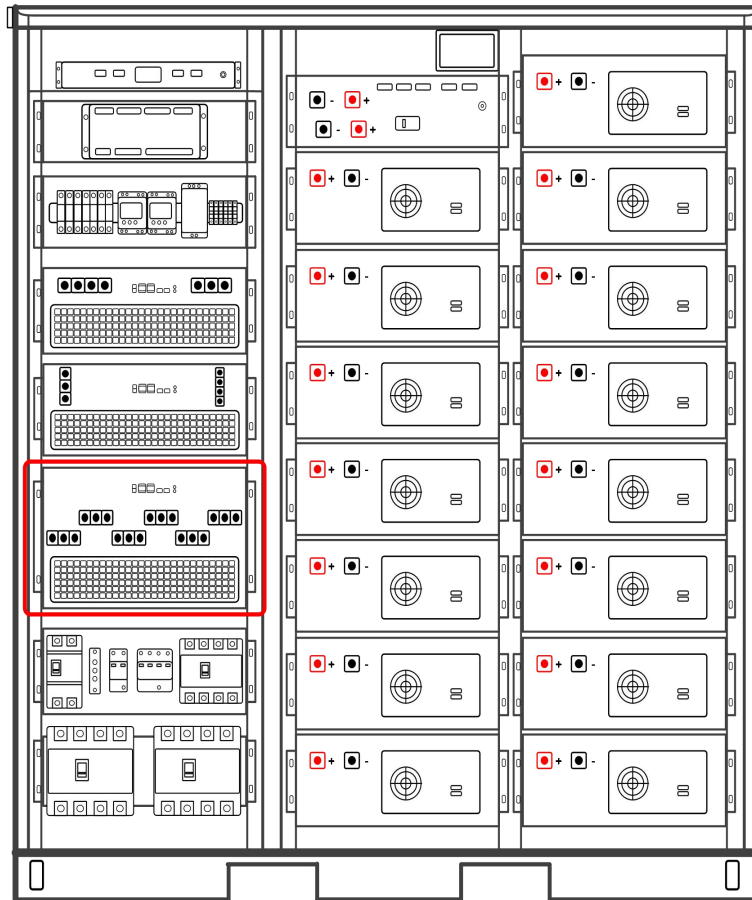

**Figure 2-13** Appearance of STS

**Module description:**

The STS system is power fast switch module. It is used for on-grid and off-grid fast switch(less than 20ms) avoiding the load power down.

**Table 2-6** Technical specification

Model	IYP-ST5200K
Rated power	200kVA
Max. power	220kVA
Rated voltage	400Vac/230Vac

Rated grid frequency	50Hz/60Hz (+/-5Hz)
Max. current	300A
Size	440*420*320mm
Weight	35kg (about)
Operating temperature	-25°C~+55°C (derating when the temperature is greater than 45°C)
Relative humidity	5~95%(without condensation)
Cooling method	Smart air cooling
Altitude	3000m(derating when the altitude is higher than 2000 m)
Communication	CAN/RS485

### 2.4.5 Air-conditioner System

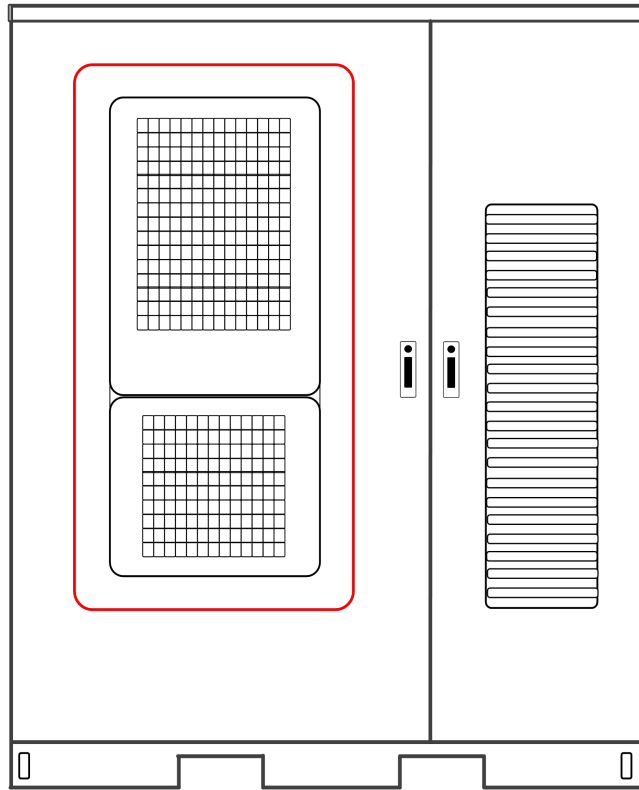

Figure 2-14 Location of A/C

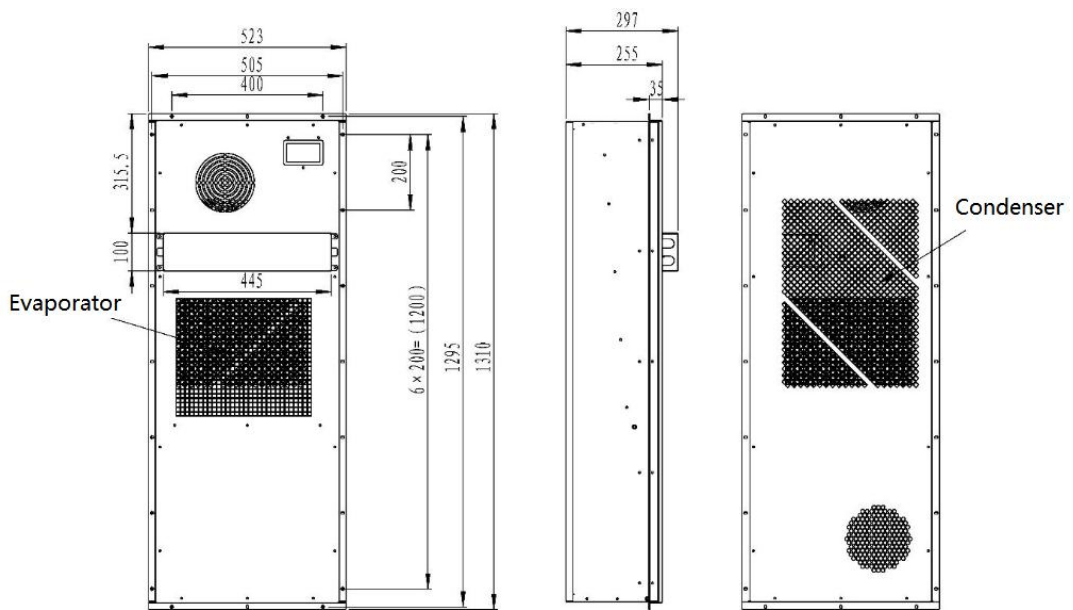

Figure 2-15 Appearance of A/C

**Module description:**

The A/C system is an intelligent Air-conditioner system. And it support cooling and heating function.

**Table 2-7** Technical specification

Item	Specification
Rated refrigerating power	3.2KW
Power voltage	230Vac (50Hz or 60Hz)
Rated power	1.6KW
Rated current	7.2A
Rated heating power	1KW
Max. work current	9.5A
Refrigerating fluid	R134A
Temperature control range	20~50℃
Humidity control	Yes
Work temperature	-40~50℃
IP grade	IP55
Size	523*255*1310mm
Weight	78kg (about)

## 2.4.6 Fire Protection System

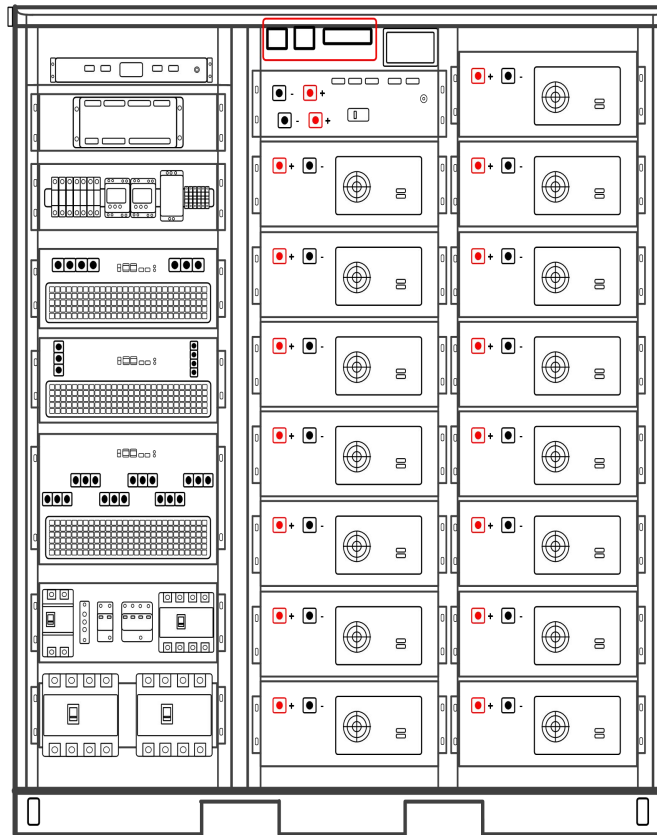

Figure 2-16 Location of FPS

### 2.4.6.1 Detector



Figure 2-17 Appearance of temperature and smoke detector

**Table 2-8** Technical specification

Item	Specification (temperature detector)	Specification (Smoke detector)
Power voltage	24Vdc	24Vdc
Rated current	Monitor: 0.3mA Action: 1.5mA	Monitor: 0.3mA Action: 1.5mA
Communication	L1/L2	L1/L2
Measure range	-40~105℃	0~400mg/m3
Work temperature	-35~85℃	-35~85℃
Size	Diameter: 100mm Height: 55mm	Diameter: 100mm Height: 55mm
Weight	70g(about)	70g(about)

### 2.4.6.2 Aerosol



**Figure 2-18** Appearance of aerosol

**Part description:**

The aerosol condensed aerosol fire suppression device is a new and world-leading type of highly efficient environment-friendly fire suppression product that is domestically pioneered in China.

When the aerosol condensed aerosol fire suppression device receives the start signal, the aerosol generator in the cartridge will be activated to decompose the chemical coolant on the upper layer so that the aerosol generator and the coolant work together to suppress a fire.

**Table 2-9** Technical parameters

Item	Specification
Executive standard for S-type condensed aerosol	GA499.1 Aerosol fire suppression system - Part 1: Condensed aerosol fire suppression device
Validity period	See the marking on the product
Start mode	Electric start/hot start
Hot start temperature	160°C~180°C
Safety current	≤200mA
Starting current	≥700mA
Extinguishing efficiency	100g/m <sup>3</sup> ~130g/m <sup>3</sup>
Protected space	3m <sup>3</sup>
Operating ambient temperature range	-40°C~+90°C
Operating relative humidity	≤95%RH
Size	68.5*46*255mm
Weight	860g(about)

## 2.4.7 Environment Control System

### 2.4.7.1 Water leak sensor



**Figure 2-19** Water leak sensor

#### Part description:

The sensor needs to be used with a transducer. The impedance changes when the water leak sensor is wet between two stages. Based on this principle, the dedicated integrated chip amplifies, shapes, and compares the wetting input signal and outputs a dry contact or high-low level change signal to indicate whether the location whether the transducer is located is wet.

**Table 2-10** Technical parameters

Item	Specification
Power voltage	24Vdc
Work temperature	-20°C ~60°C
Operating humidity	0%RH ~100%RH
Size	48*48*30mm
Weight	50g(about)

## 2.5 Operating Principle 2.5.1 1 Circuit Block Diagram

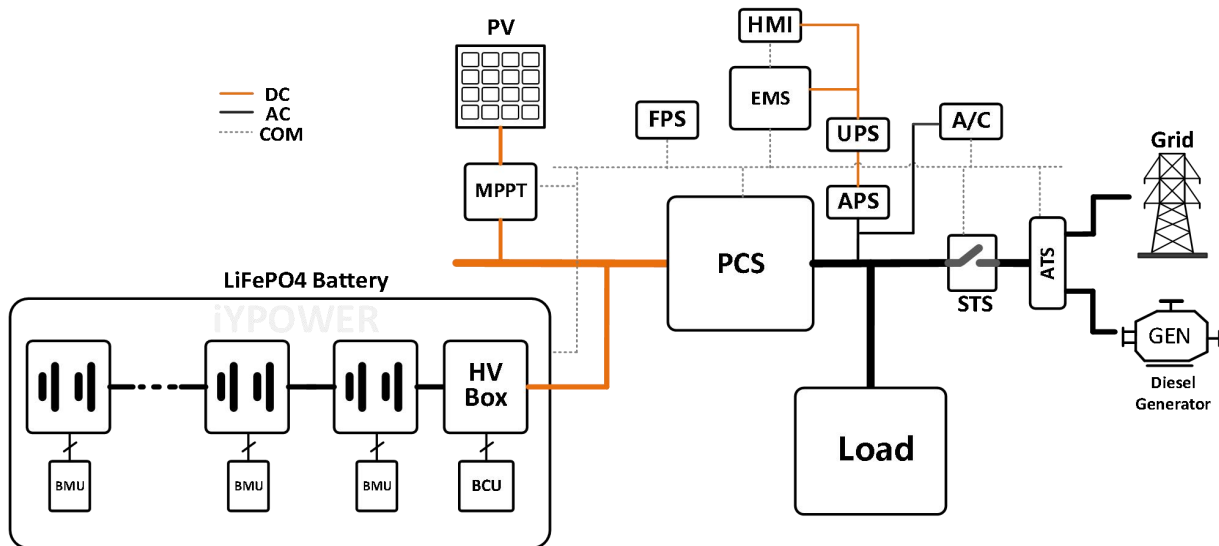

Figure 2-20 System topology

### 2.5.2 Equipment States

There are five states for the energy storage system including running, shutdown, fault, standby, and offline.

Table 2-11 Description of equipment states

Equipment States	Description
Running	The energy storage system stores external direct current into battery packs or discharges battery packs' electric energy to outside units.
Shutdown	The energy storage system stops charging and discharging and powers off battery packs.

Fault	The equipment is faulty when a fault is detected.
Standby	The equipment is in standby mode.
Offline	The EMS is disconnected from the display screen.

## 2.6 Typical Applications

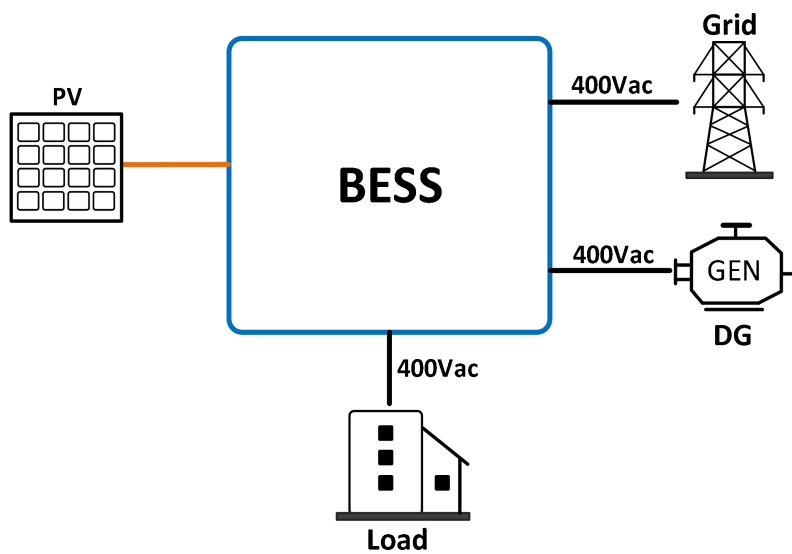

Figure 2-21 DC coupling

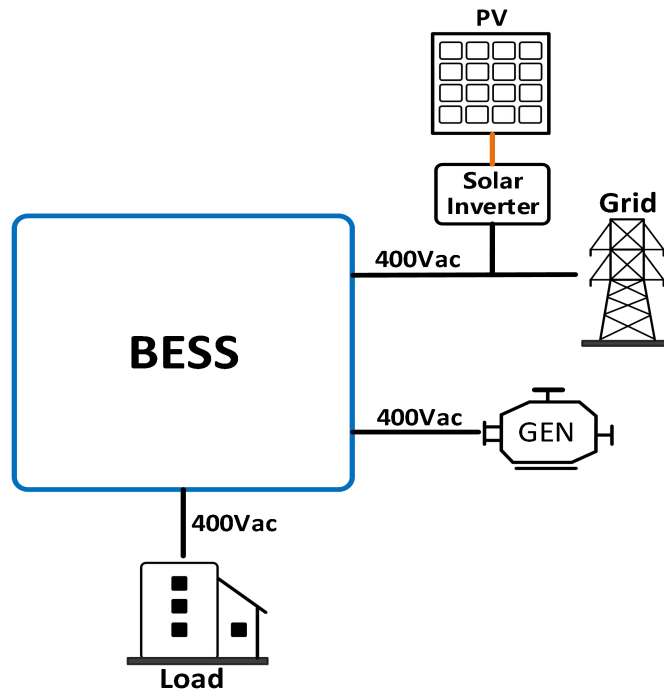

Figure 2-22 AC coupling

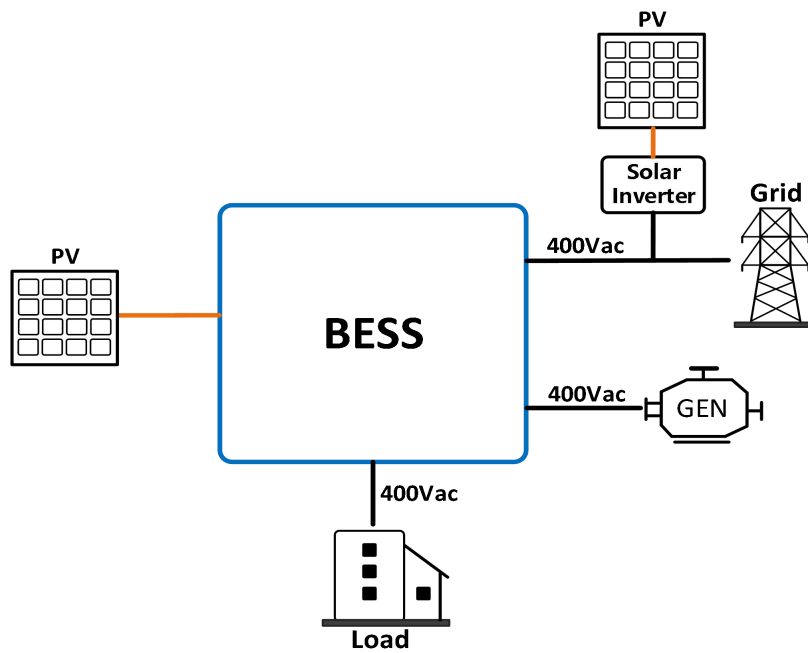

Figure 2-23 DC and AC coupling

## 3 Site Requirements

### 3.1 Site Selection Requirements

#### Notice

The site should be selected according to GB51048 Design code for electrochemical energy storage station, NFPA855 Standard for the installation of stationary energy storage systems, and local laws and regulations.

The energy storage system is suitable for outdoor applications and deployed outdoors. For indoor applications, refer to local laws and regulations. General site selection requirements:

- The system should not be installed in low-lying areas, and the installation level should be greater than the highest water level on records in this area.
- There should be at least a 2km distance from the airport, landfill, river bank or dam.
- Select an open location and ensure that there are no obstacles within 10m of the site.
- Keep at least 50m away from residential areas to avoid noise pollution.
- The installation area shall have convenient transportation conditions and be equipped with a reliable fire suppression system.
- The future requirements for the site area must be taken into account, and there should be sufficient reserve space for future needs throughout the life cycle.
- Select a well-ventilated place.
- The energy storage system, when installed in a place subject to salt damage, may be corroded and thus cause fire hazards. Do not install the energy storage system outdoors in salt-affected areas. Salt damage areas are those within 2km of the coast or affected by sea breezes. The areas affected by sea breezes vary with meteorological conditions (for example, typhoons, and seasonal winds) or topographical conditions (for example, dams and hills).

#### Description

1. It is recommended to relocate the site When the safety distance cannot meet the requirements of

*applicable national standards.*

*2. If there is no more suitable site, it is recommended to install a fire division wall capable of resisting fire for no less than 3hours for security protection purposes, and the space requirements for equipment transportation, installation, and maintenance shall be taken into account.*

*3. As recommended in T/CEC 373-2020, the length and height of the fire division wall shall exceed the outer contour of the prefabricated module by 1m each, and as described in NFPA 855-2020 Standard for installation of stationary energy storage systems, the spacing can be reduced to 914mm when there is an independent fire division wall capable of resisting fire for at least 1hour.*

Site selection should avoid scenarios that are not recommended by industry standards and regulations, including but not limited to the following locations, regions, and venues:

- Areas with strong vibration, strong noise source and strong electromagnetic field interference.
- A place where dust, oil fumes, harmful gases, or corrosive gases are produced or exist.
- A place where corrosive, flammable or explosive materials are produced or stored.
- Places with existing underground facilities.
- Ground with adverse geological conditions such as rubber soil and soft soil layer, and ground prone to water accumulation and subsidence.
- Earthquake area with earthquake fault and fortification intensity greater than 9 degrees.
- Areas with direct hazards such as debris flow, landslides, quicksand or karst caves.
- Within the boundary of mining subsidence (fault dislocation)areas.
- Within the range of blasting hazard.
- Areas likely to be flooded if a dam or levee breaks.
- Important water source sanitation protection area.
- Protected areas of historical relics and monuments.
- Crowded places, high-rise buildings, and underground buildings.

### 3.2 Forklift Requirements

- Before using the forklift, ensure that the forklift meets the load-bearing requirements: The load-bearing capacity must be at least 5tons.
- The recommended fork length is at least 1.5m.

### 3.3 Lifting Requirements

- Before lifting operation, ensure that the crane and rope meet the load-bearing requirements. The energy storage system must be lifted using a lifting bracket.
- Do not drag the lifting equipment on the cabinet to prevent it from being scratched during installing or removal operation.

Lifting Process	Precaution
Before lifting	Crane lifting capacity>5tons,working radius≥2m.Consult a professional to evaluate the working conditions on site when on-site conditions are not met.
	A lifting operator shall receive training and be certified before starting the lifting operation.
	The lifting appliances shall be tested and checked for completeness.
	Ensure that the lifting appliances are firmly fixed to a rigid structure or wall that meets the load-bearing requirements.
	It is recommended to perform lifting operations in clear weather without high wind in outdoor applications.
	Check that the crane and wire rope meet requirements before lifting operation.
	All the equipment doors are tightly closed.
	Check that the wire rope is safely and reliably connected.
	It is recommended to perform lifting operations from left to right or right to left to ensure smooth operation.
During lifting	Do not enter the lifting area without authorization or stand underneath the crane jig.

---

	Ensure that the crane is properly positioned and do not allow long-distance lifting operations.
	Keep the cabinet stable with a diagonal inclination not more than 5°.
	Ensure that the angle between wire ropes is not more than 90°.
	Handle the crane with due care. Gently and smoothly lower the cabinet to avoid impact on the equipment inside.
	Wait until the cabinet contacts the base and the base is uniformly stressed before removing the lifting rope.
	Do not drag wire ropes and slings during lifting operations to avoid impact.
	Fix the cabinet you have lifted and then proceed with lifting other cabinets.

## 4 Installation

### 4.1 Preparations before Installation





#### 4.1.1 Tools



 Description



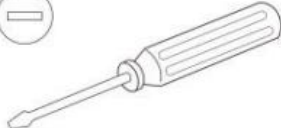
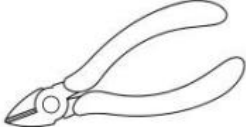

- The tools given here are for reference only.
- The tool list may not list tools that may be rarely used on site, depending on site conditions.

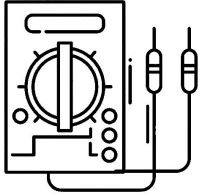
On-site installers and users are advised to prepare tools that are not listed.

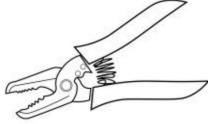
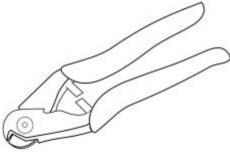
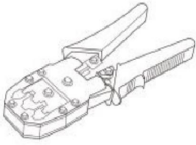
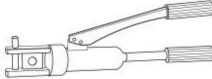
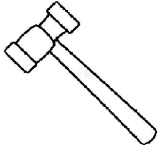
#### Installation Tools

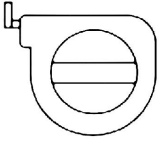
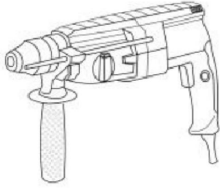

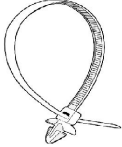
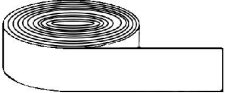
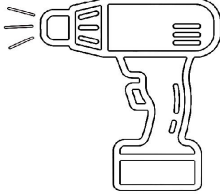
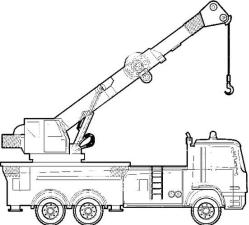
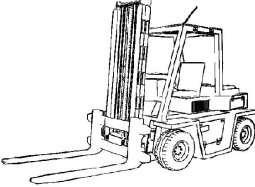

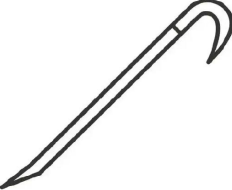

  <p>Phillips insulated torque screwdriver</p>	 <p>Insulated torque socket wrench (including extension bar)</p> <ul style="list-style-type: none"> <li>• Socket specification: 7mm to 19mm</li> <li>• Socket depth <math>\geq</math> 32mm</li> <li>• The socket coupling matches the torque wrench</li> </ul>	  <p>Slotted insulated torque screwdriver</p>	 <p>Diagonal pliers</p>
--	---	--	--

	<ul style="list-style-type: none"> <li>• Torque range: 1.2N·m to 45N·m</li> </ul>		
 <p>Multimeter with DC voltage measuring range <math>\geq 1500Vdc</math></p>	 <p>Allen wrench: 5mm to 12mm</p>	 <p>Utility knife</p>	 <p>Wire stripper</p>
 <p>Wire cutter</p>	 <p>Crimping tool</p>	 <p>Hydraulic tongs</p>	 <p>Rubber hammer</p>

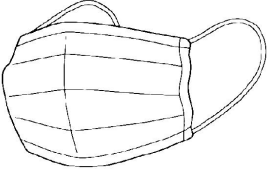
 <p>Spirit level</p>	 <p>Steel tape</p>	 <p>Impact drill</p>	 <p>Drill bit Φ16mm</p>
 <p>Cable tie</p>	 <p>Heat shrink tubing</p>	 <p>Hot air gun</p>	 <p>Vacuum cleaner</p>
 <p>Crane</p>	 <p>Forklift</p>	 <p>Manual forklift</p>	 <p>Insulating ladder</p>
	 <p>Lifting rope and lifting</p>		

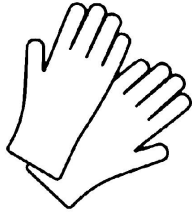
Crowbar	eye, rope length $\geq$ 5000mm $\times$ 2		
---------	---	--	--

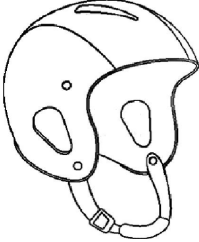
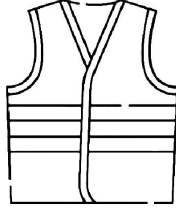
**PPE**

 <p>Dust mask</p>	 <p>Goggles</p>	 <p>Protective gloves</p>	 <p>Insulating gloves</p>
 <p>Insulating shoes</p>	 <p>Safety helmet</p>	 <p>Reflective vest</p>	 <p>Safety belt</p>

---

## 4.1.2 Checklist before Installation

### Checking Outer Package

Before unpacking, check the outer package for visible damages, such as holes, cracks, or other signs of possible internal damage, and check the device model against the packing list. For any packaging defect or incorrect device model, do not unpack and immediately contact your vendor.

#### Description

You are advised to unpack the cabinet within 24 hours before installing it.

---

#### Warning

If the cabinet is more than 2 m high, please take protective measures for working at heights when removing the outer package.

---

### Checking Deliverables

Check the deliverables for completeness or visible appearance damage before removing the outer package. For any omission or damage, contact your vendor.

## 4.2 Installing Energy Storage System and Cables

### Precaution

---

#### Danger

- Before making electrical connections, please ensure that all switches of the energy storage system are in the "OFF" position. Otherwise, the high voltage that exists in the energy storage system may lead to electric Shock.
- 
-

 **Warning**

- Equipment damage caused by improper connection shall not be covered by the warranty.
- Only an electrical engineer can make electrical connections.
- An operator shall wear PPEs during electrical connections.

 **Description**

The cable colors in the electrical connection diagrams in this section are for reference only. The cables must be selected in strict accordance with local cable standards. The yellow and green cables can only be used for protective earthing

## Cable Requirements

For crimping OT/DT terminals, *see A Crimping OT/DT Terminals.*

Name	Type	Conductor Cross Section Area Range	Description
AC incoming line	3-conductor Copper core/ copper-clad aluminum/ aluminum alloy cable for Out door use	>70mm <sup>2</sup>	User-supplied

AC line for auxiliary power supply	2-conductor(LN) copper core/ copper-clad aluminum/ aluminum alloy cable for Out door use	>6mm <sup>2</sup>	User-supplied
PE cable	Single-conductor Copper core/ copper-clad aluminum/ aluminum alloy cable for Out door use	25mm <sup>2</sup> ~50mm <sup>2</sup>	User-supplied The specification of the PE cable is determined according to this table, or calculated according to IEC 60364-5-54.

## Installation Procedure

**Step 1** Remove the outer package of the energy storage system

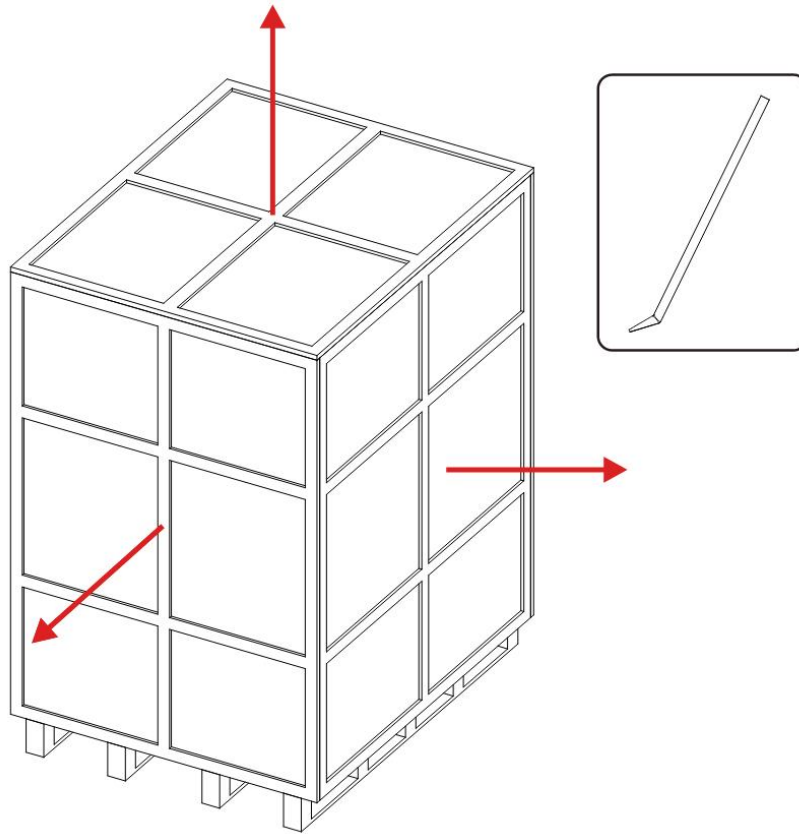

**Figure 4-1** Remove the outer package

**Step 2** Remove the front and rear plates

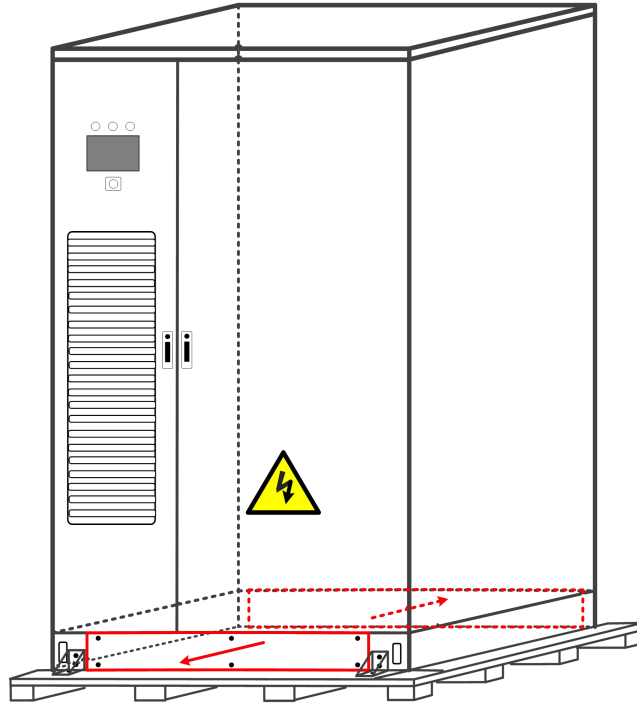

**Figure 4-2** Remove the front and rear plates

**Step 3** Remove the pallet

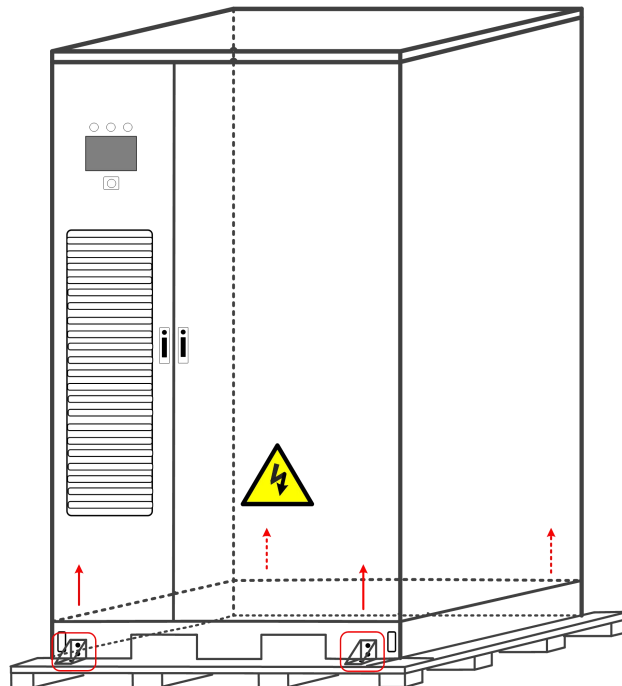

**Figure 4-3** Remove the pallet

**Step 4** Drill holes on the installation foundation and install expansion screws

(M16×100, four screws)

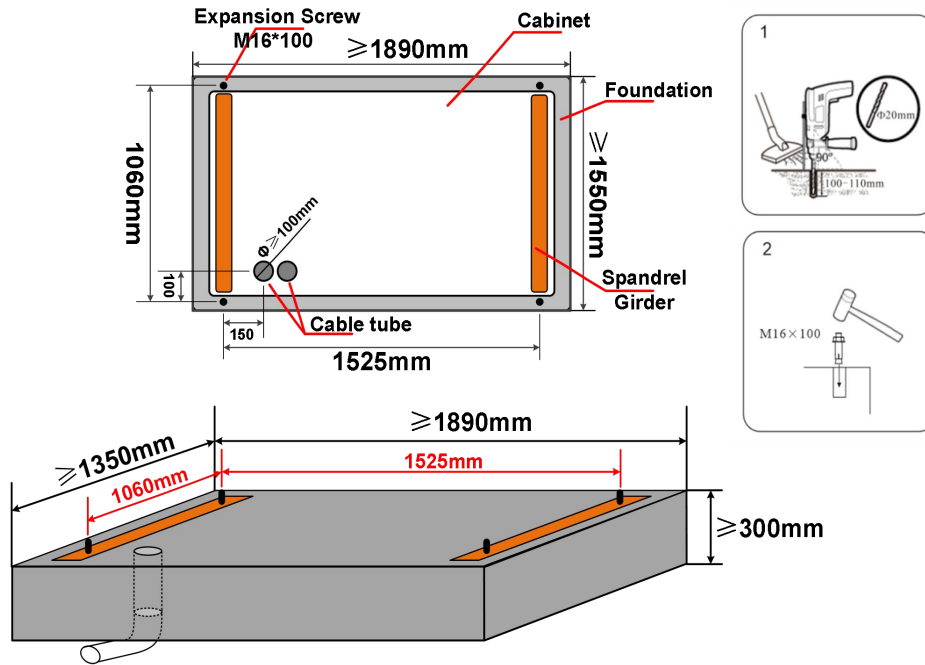

**Figure 4-4** Drill holes and install expansion crews

**Step 5** Use a forklift to move or lift the equipment to the installation platform

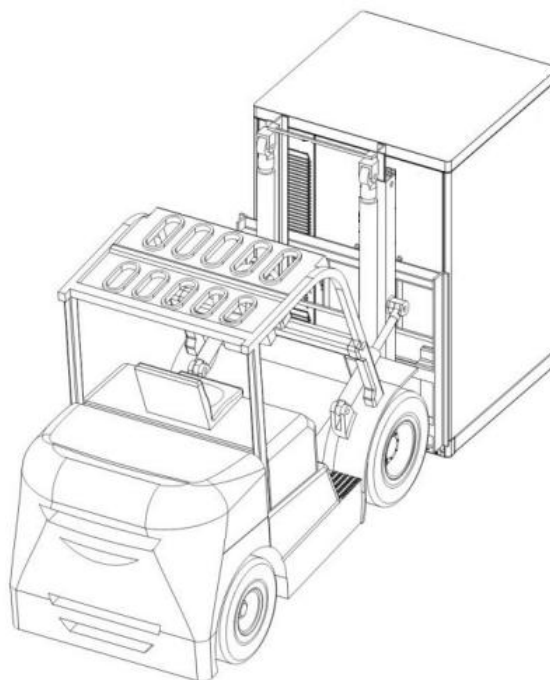

**Figure 4-5** Use forklift to move and install

**! Notice**

When a forklift is used to move the equipment, bind and fix the equipment according to site conditions to prevent tipping over.

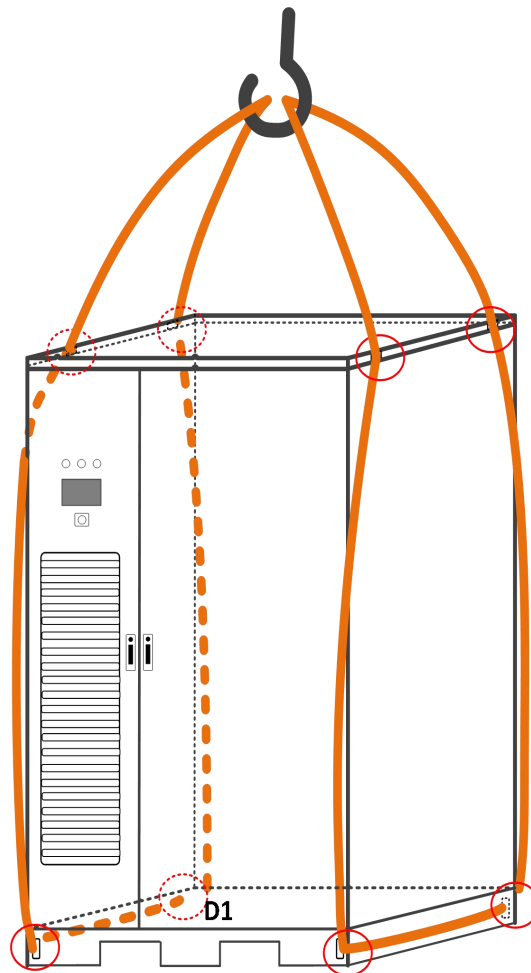

**Figure 4-6** Lift to the installation platform

**Step 6** Fix the energy storage system

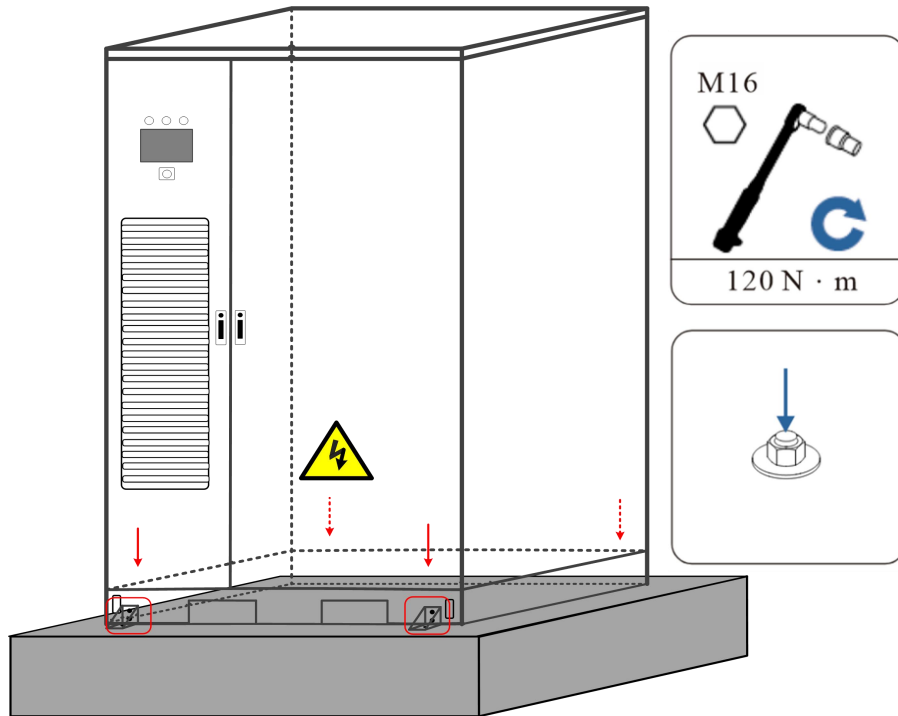

**Figure 4-7** Fix to the installation platform

**Step 7** Install the PE cable

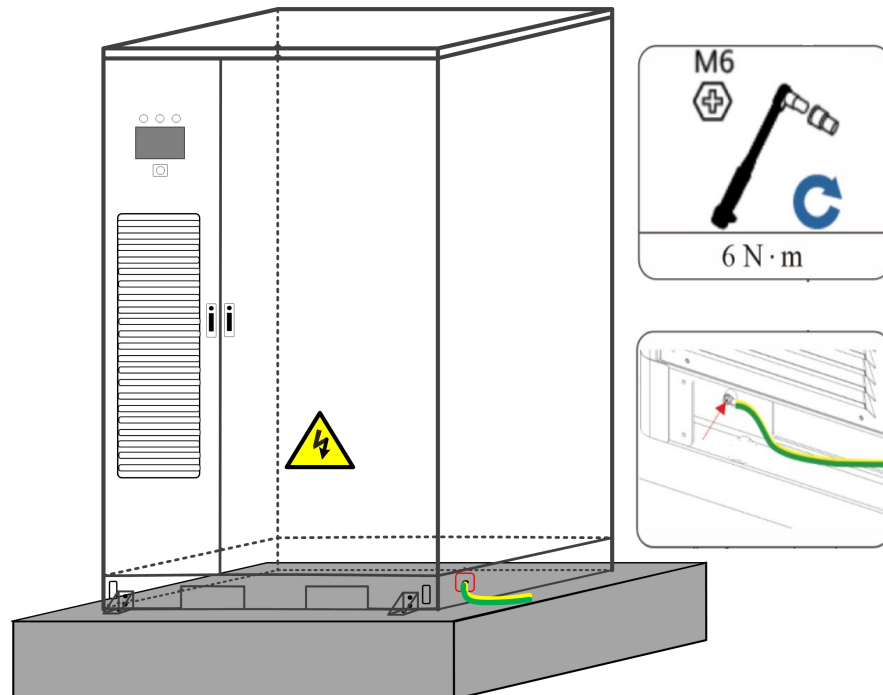

**Figure 4-8** Install the PE cable (front)

**Step 8** Install the front and rear panels.

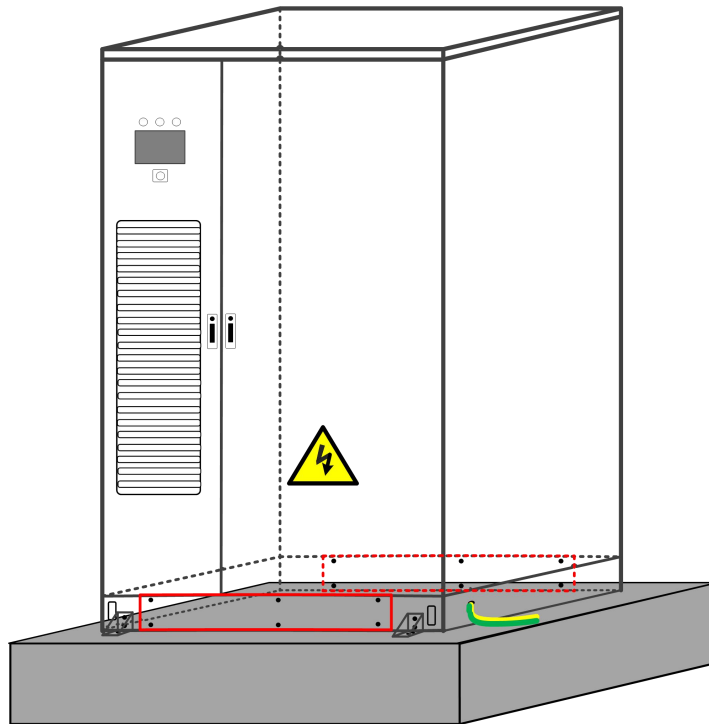

**Figure 4-9** Install the front and rear panels

**Step 9** Open the front door of electric

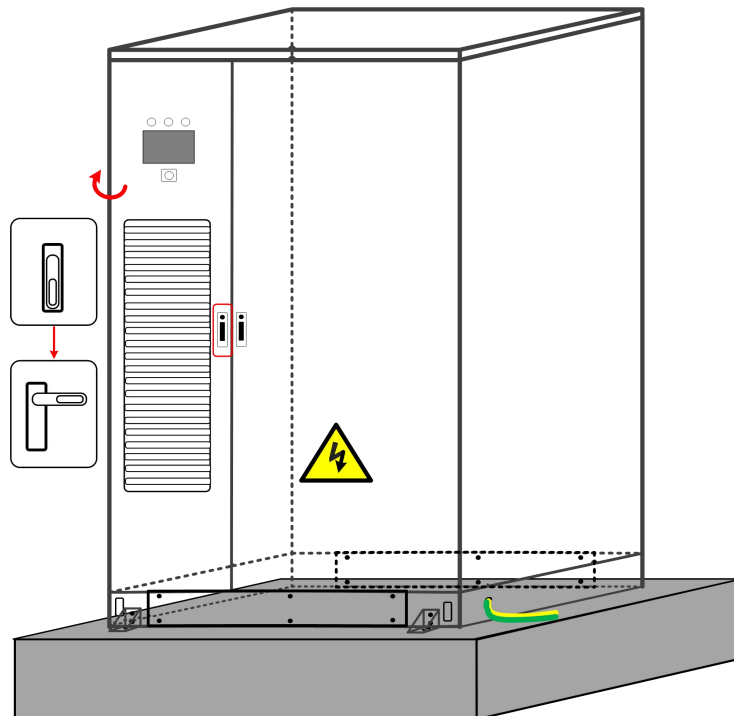

**Figure 4-10** Open the front door

**Step 10** Install the power cable(PV/Grid/DG/Load)

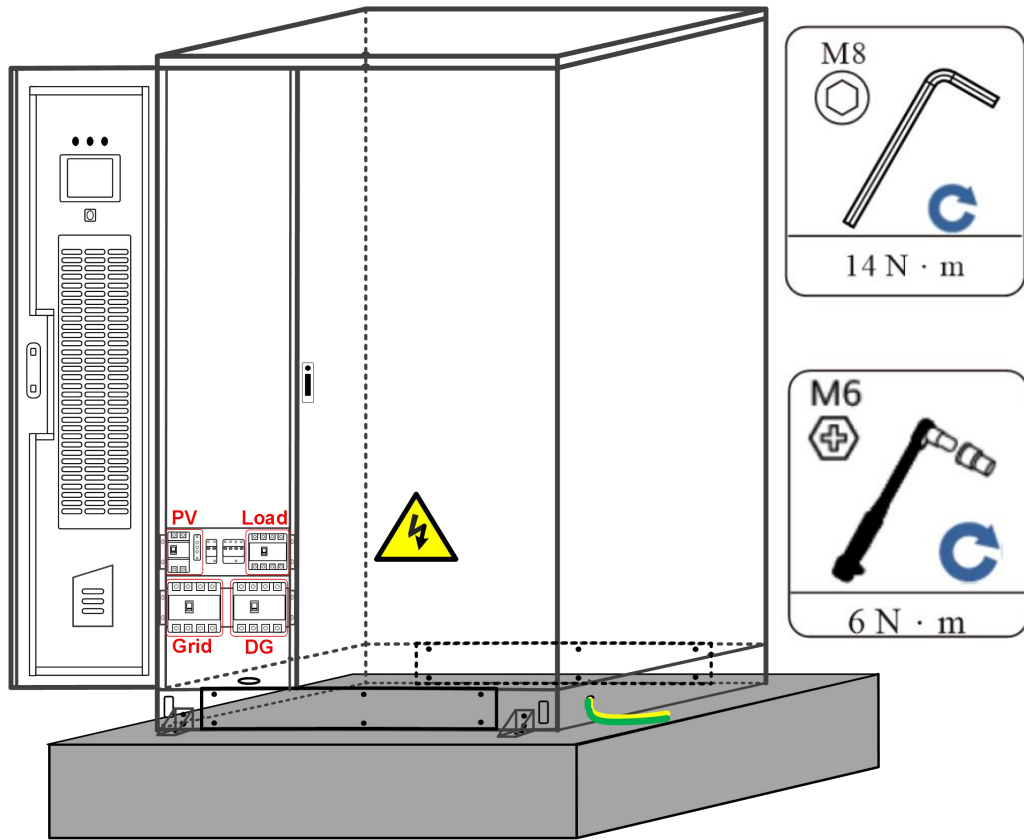

**Figure 4-11** Install the power cable

**Step 11** Close the front door of electric

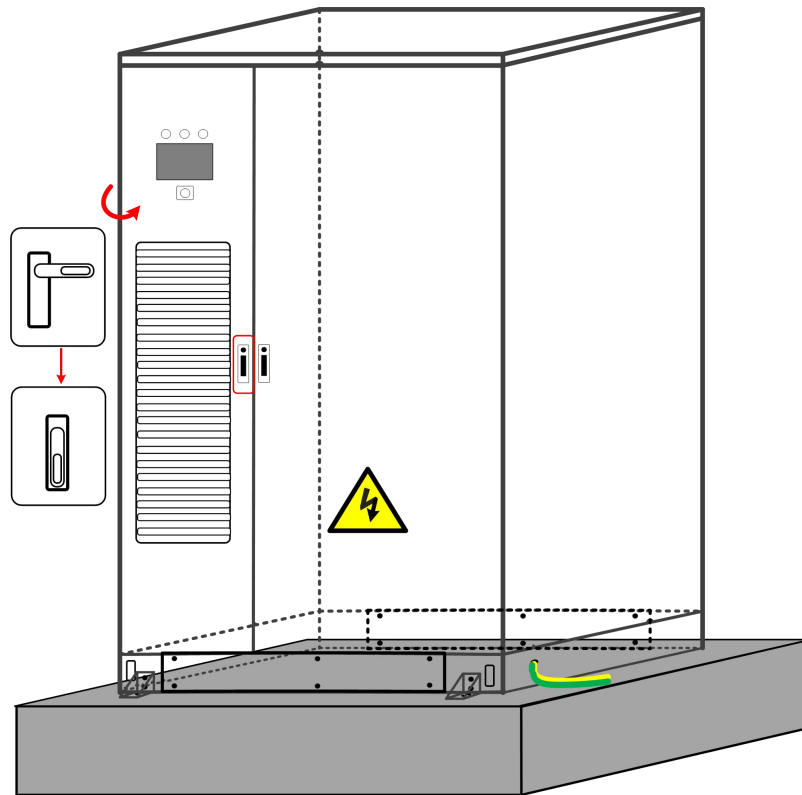

**Figure 4-12** Close the door

## 5 Power On

### 5.1 Checklist before Power On

#### 5.1.1 Routine Check

SN	Check Item	Acceptance Criteria
1	Equipment appearance	<ul style="list-style-type: none"> <li>● The equipment is free of appearance defect, damage, rusting or painting defect. If painting peels off, please repair the paint.</li> <li>● The label on the equipment is legible. Replace a damaged label immediately.</li> </ul>
2	Cable appearance	<ul style="list-style-type: none"> <li>● The cable sheath is intact and free of visible damage.</li> <li>● The cable duct is in good condition.</li> </ul>
3	Cable connection	<ul style="list-style-type: none"> <li>● Cable connections are consistent with the design drawing</li> <li>● Terminals are manufactured in strict accordance with standards and securely and reliably connected</li> <li>● Labels at two ends of various cables are legible and uniformly oriented.</li> </ul>
4	Cable layout	<ul style="list-style-type: none"> <li>● HV cables and LV cables are properly routed and separated</li> <li>● Cables are routed in a pleasant style.</li> <li>● Cable connectors are cut to a proper length without burr.</li> <li>● Suitable length is reserved at turns as required. Do not pull cables tight at turns.</li> <li>● Cables are routed straightly and smoothly without crossing in the cabinet</li> </ul>
5	Copper bar in the lithium Battery pack	The copper bar is not deformed and the PVC coating is not damaged.
6	Switch	<ul style="list-style-type: none"> <li>● The circuit breaker of the distribution cabinet is in OFF position.</li> <li>● The HV box switch is in the OFF position.</li> </ul>

## 5.1.2 Checking the Installation of the Energy Storage System

### Checking Cabinet

SN	Check Item	Acceptance Criteria
1	Installation	<ul style="list-style-type: none"> <li>The energy storage system is installed in accordance with the design drawing.</li> <li>The cabinet is installed on a level surface and cabinet doors can be normally opened.</li> </ul>
2	Appearance	The surface of the cabinet is free of cracking pitting, or scratching. If painting peels off, please repair the paint.
3	Grounding of the cabinet	Each cabinet has at least two grounding points and is reliably grounded with grounding resistance not more than 0.1Ω.
4	Accessories	The number and location of installed accessories meet design requirements.
5	Marking	The marking is correct, legible, and complete.

### Checking Cabinet Inside

SN	Check Item	Acceptance Criteria
1	Circuit breaker	The circuit breaker is open.
2	Copper bar	The copper bar is not obviously deformed and free of foreign matters.
3	Cables	Cable mounting bolts are tightened and cables are not loose when pulled
4	Blockage of cable holes	Cable holes are blocked.

5	LiFePO4 battery pack	Each LiFePO4 battery pack is free of appearance defect.
6	Foreign matters	Clean up foreign matters inside the cabinet, such as tools or excess materials.
7	Shield plate for the power distribution area	The shield plate for the power distribution area is free of cracking pitting, scratching or looseness.
8	Parts (detector, FPS, high voltage box,circuit breaker)	Parts are free of appearance defects.
9	Grounding of the cabinet	The grounding conductor is reliably connected to the grounding terminal board or the copper bar of the cabinet.

### 5.1.3 Checking the PCS

Check Item	Description
Checklist of electrical connections	Check whether the preceding AC circuit breaker switch and the DC switch of the HV box are in the OFF position.
	Check that all cables are not damaged or cracked and ensure that all cables are in good condition.
	Check whether all the ground cables are securely connected.
	Check whether all AC cables are correctly, securely, and reliably connected, without break or short circuit.
	Check whether the polarity of the DC cable is correct and whether it is securely and reliably connected without break or short circuit.
	Check whether the front and rear cabinets of the PCS are clean and tidy and ensure that there are no construction residues.
	Check whether the front and rear shutters are closed and whether the screws on the door are tightened.

## 5.2 Power-On Procedure

Procedure	Items	Remark
1	Turn on the power switch QF2/QF3/QF4. Power on the on-grid AC power, PV power and DG power in the distribution cabinet	The SPD is turned on by default No manual intervention is required
2	Turn on Q1 and power on the auxiliary power supply	230V main power switch of auxiliary power supply
3	Turn on Q2 to Q5 in turns	Supply power to the HV box, UPS, A/C, FAN etc.
4	On the UPS, press and hold the ON/OFF button to start AC power output.	Hold and press the ON/OFF button until the LCD is light.
5	Turn on the switch QF1 of the main control box, and issue a power-on Command. The battery cabinet will automatically close the HV relay upon completion of pre-charging. In this case,the positive and negative output poles of the battery cabinet will produce high DC voltage.	After the power-on command is issued, the relay pulls in, and the DC side produces DC voltage.
6	Turn on the switch QF5. And the load is power on.	
<p>Note a: Check whether the auxiliary AC supply voltage is within the specified voltage range (230V±10%) before closing the auxiliary power supply switch of the energy storage system.</p>		

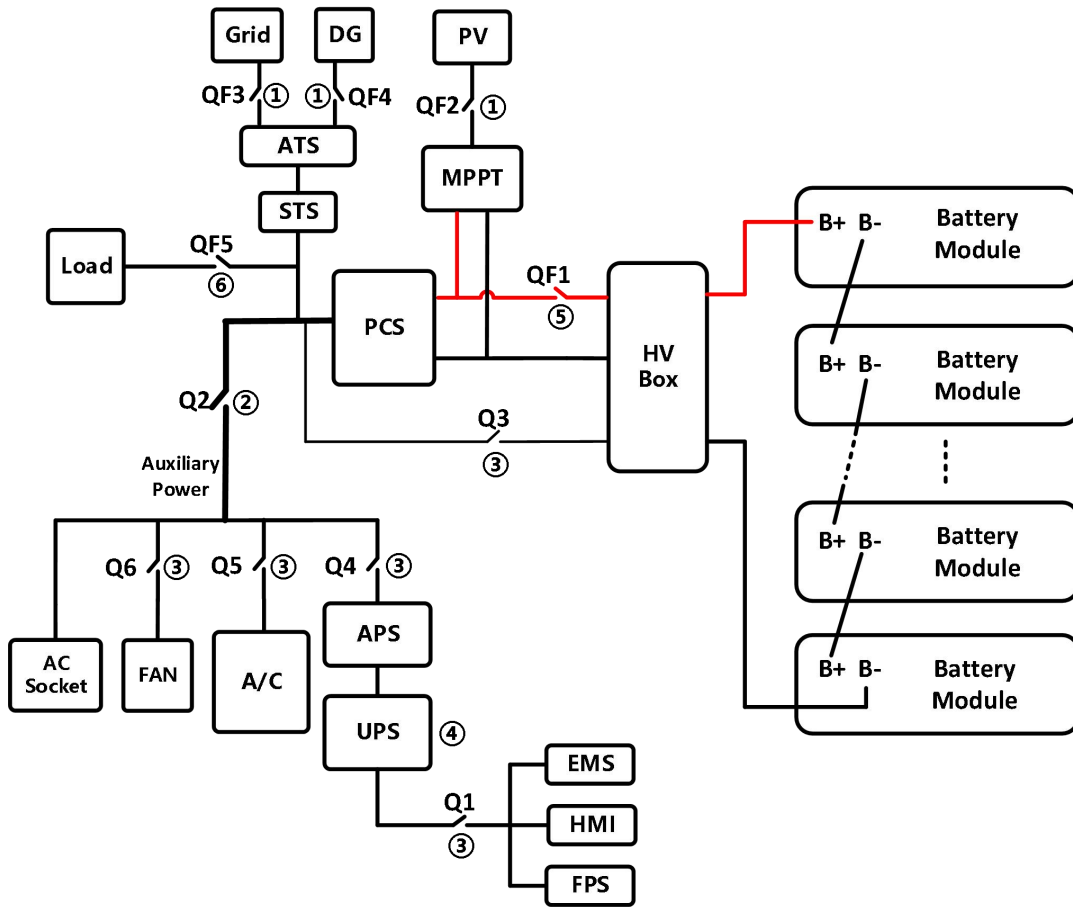

Figure 5-1 Power on procedure

## 6 Power-on Commissioning

### Preconditions

1. All devices on site are commissioned upon delivery.
2. The system can be normally powered on and alarms are cleared.
3. Boot commissioning equipment for gets ready on site

### 6.1 Getting Ready and Accessing On-line

#### Operation Procedure

After the auxiliary power supply is turned on, the touchscreen on the front cabinet door is turned on and you are directed to the screen.

### 6.2 Boot Wizard

On this screen, the home page is as follow. It contains BESS information and status. And the right side is system topology. The bottom is function button 'Data', 'Status', 'Set'.

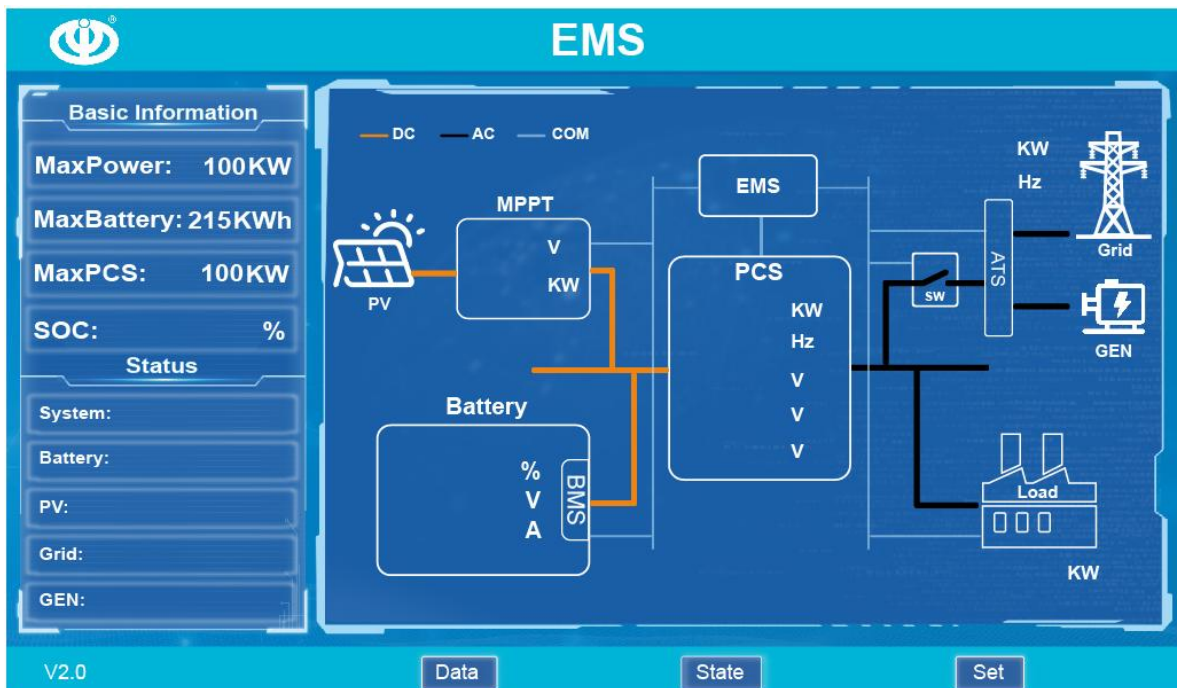

Figure 6-1 EMS home

- Data: You can view Battery and BMS, PCS, MPPT, A/C, FPS, Meter, and other information.

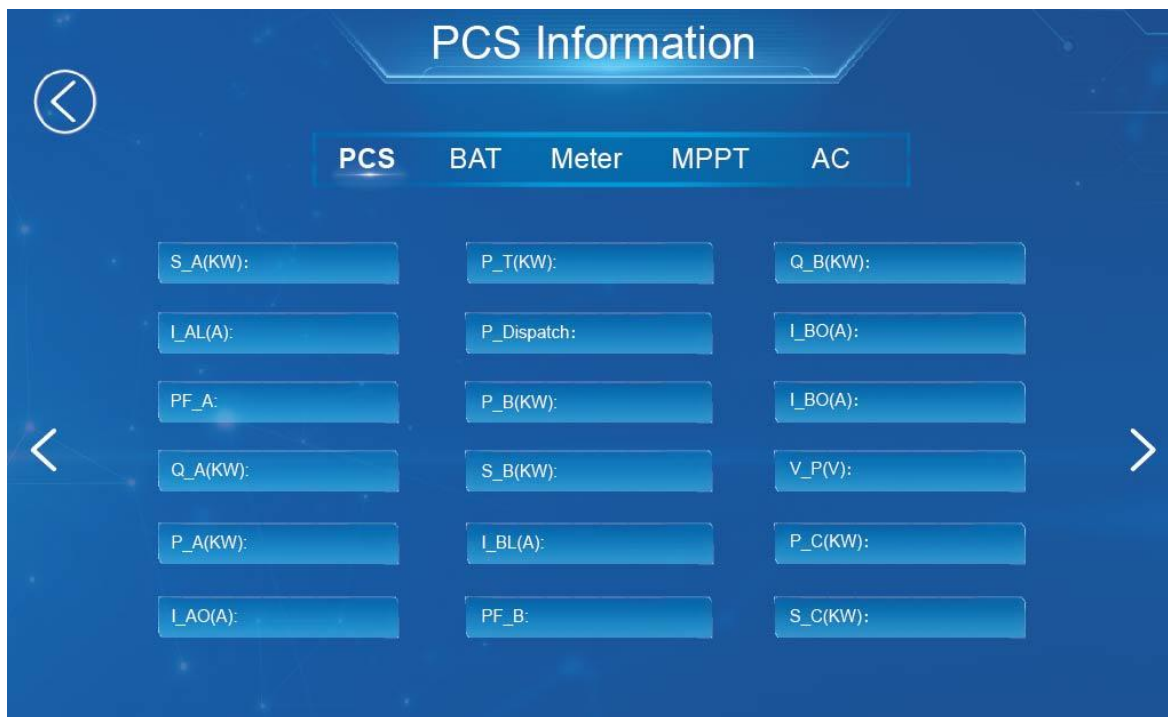

Figure 6-2 Module information

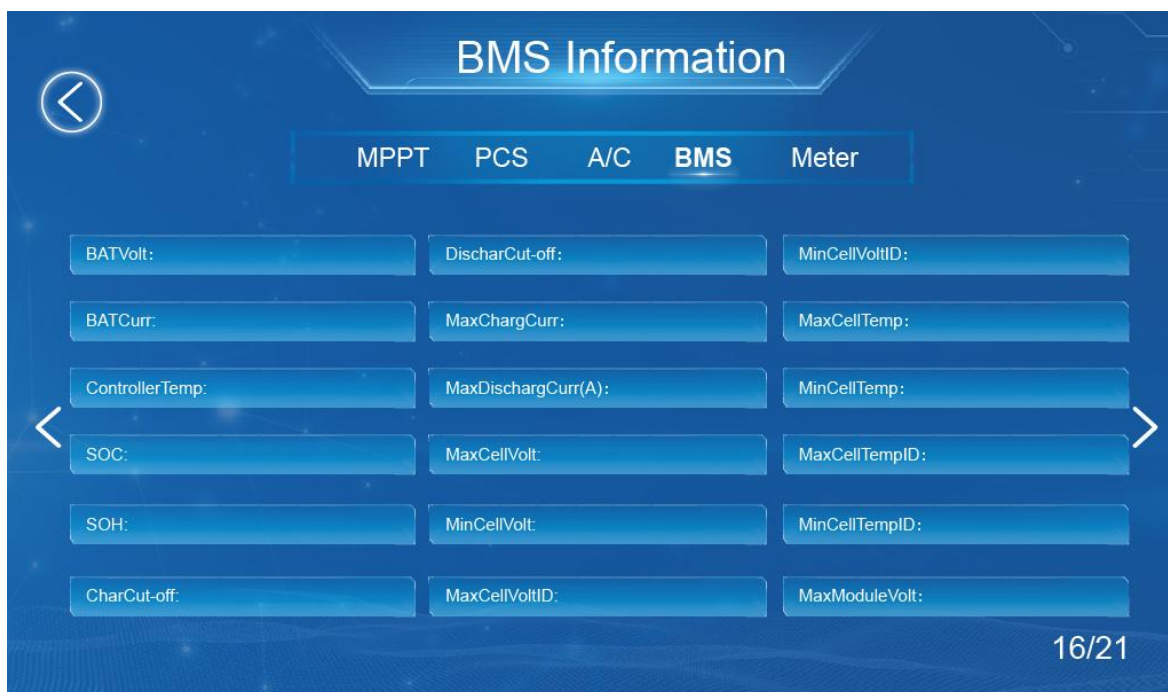

Figure 6-3 Battery&BMS data

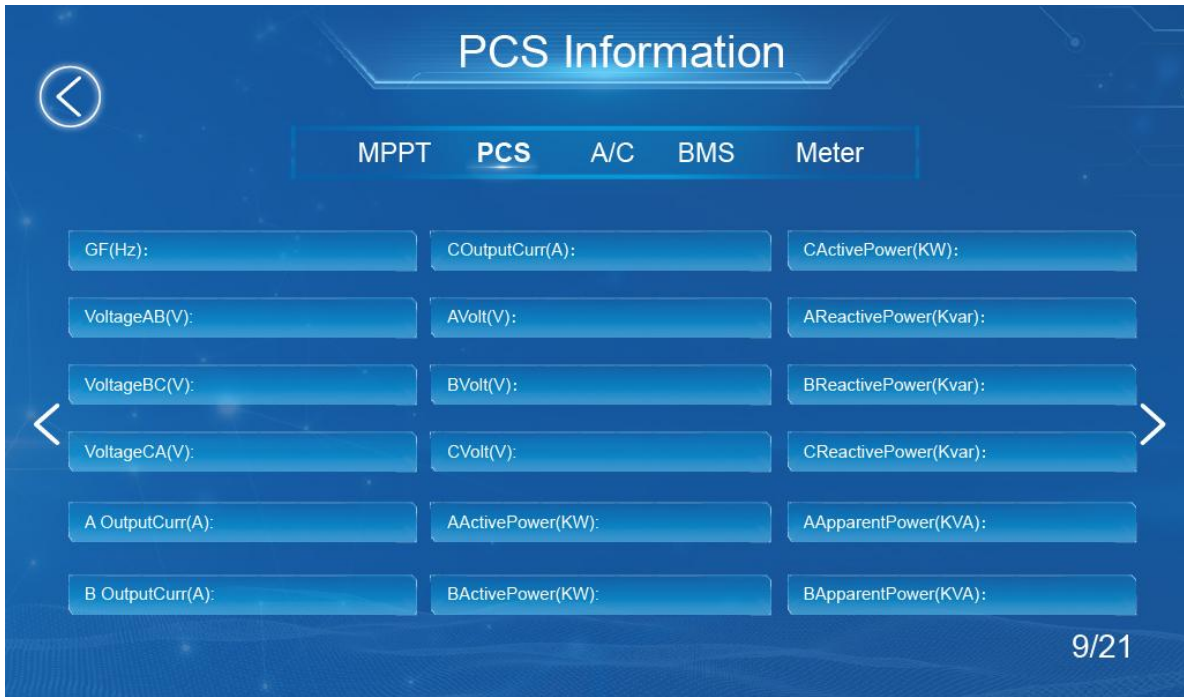

Figure 6-4 PCS data

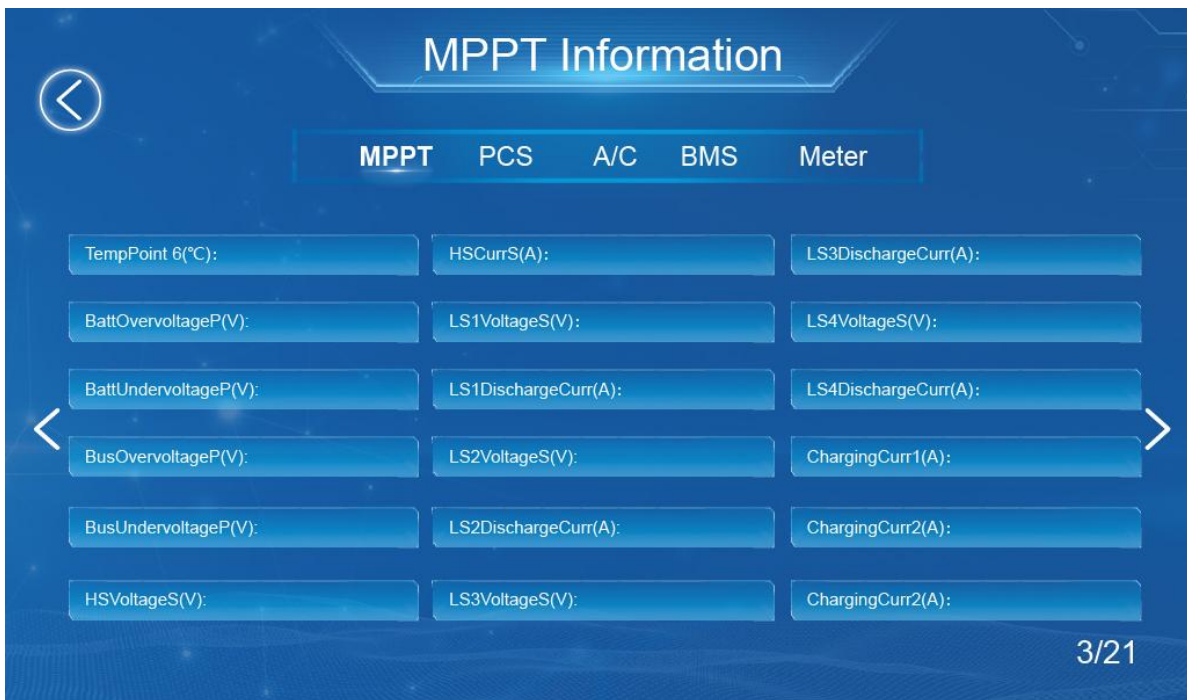

Figure 6-5 MPPT data

- Status: You can view the module Battery&BMS, PCS, MPPT, A/C, FPS and other module work status. Such as warning and fault information.

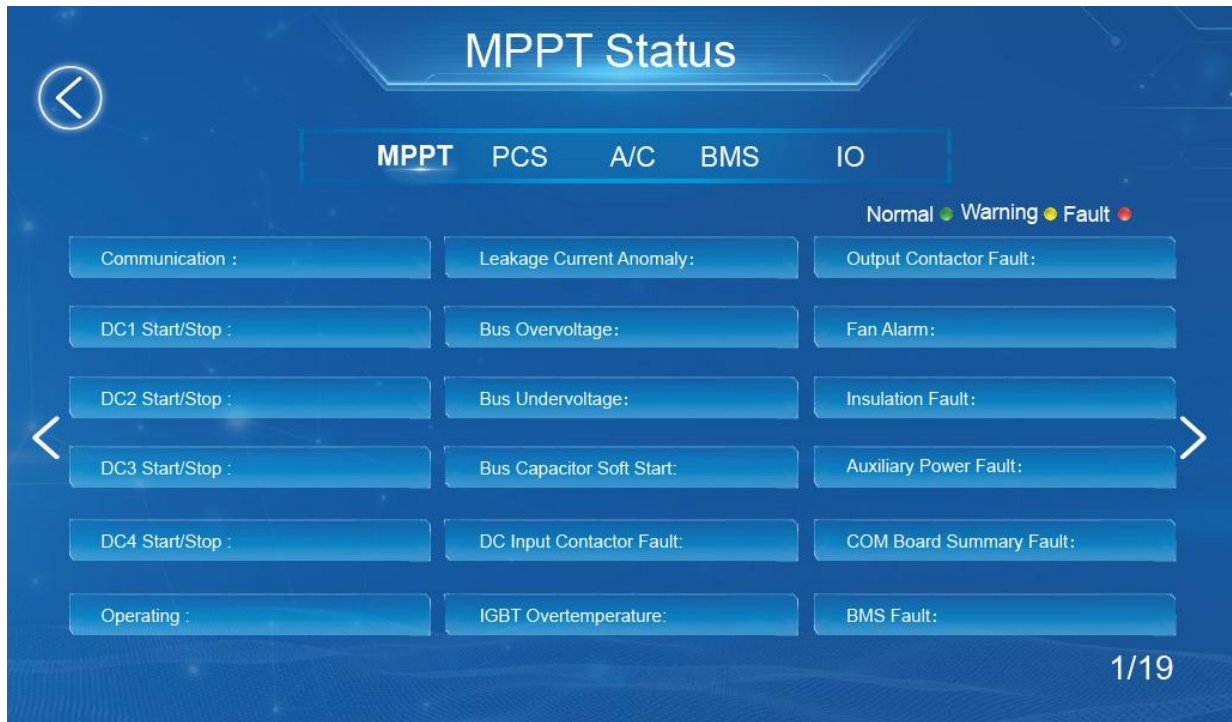

Figure 6-6 Module status

- Set: You can set the parameters of some modules.

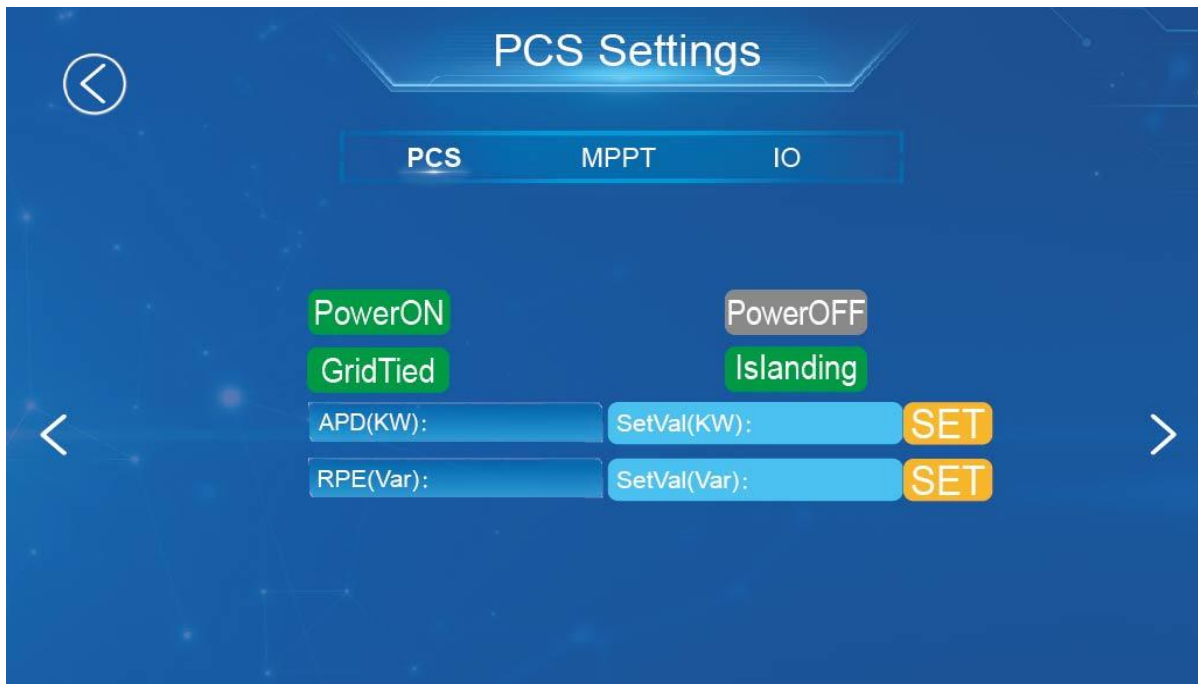

Figure 6-7 Parameter set

On the System Control screen, you can turn on/off battery (power on/off), set control mode, issue power, and set SOC and power factor.

Among these, in Manual mode, you can implement local control on the screen.

## 6.3 Communication Interface Configuration

### 1. Prepare tools

- ① Computer
- ② RJ45 cable

---

## 2. Set the steps

- ① Connect the computer to the LAN port of the TP-LINK router and automatically obtain the address of 133.144.155.0/24
- ② Enter 133.144.155.1 to log in to the router management interface; Login account: admin password 123456@iyp
- ③ Change the IP address of the wan port (a private IP address that accesses the public network is required, and can be changed onsite).
  
- ④ Restart the router to test whether the public network can be accessed

---

## 7 Power Off

### 7.1 Shutdown Command

#### Operation Procedure

**Step 1** On the screen, click "System Control > Shutdown" to implement the shutdown command.

**Step 2** Click "Monitoring > PCS " to check system status, power, and DC-side voltage and check that the shutdown sequence is executed.

**Step 3** Click "Monitoring > BMS" to view running status and check that the shutdown sequence is executed successfully.

## 7.2 Power-off Procedure

Table 7-1 Power-off procedure

Procedure	Item	Remark
1	It can issue the shutdown command to power off the DC side on screen. Then manually turn off the switch QF1.	The system is shut down. In this case, the primary circuit of the electric control cabinet is disconnected and the positive and negative output poles has no high voltage.
2	On the UPS, you need to press and hold the ON/OFF button to turn off the AC power supply.	
3	Turnoff Q3 to Q6 in turns	Cut off the UPS and other power supplies.
4	Turn off Q2	Turn off the 230V main power switch of auxiliary power supply
5	Turn off the Grid/DG/PV/Load breaker QF2/QF3/QF4/QF5	Cut off the input and output

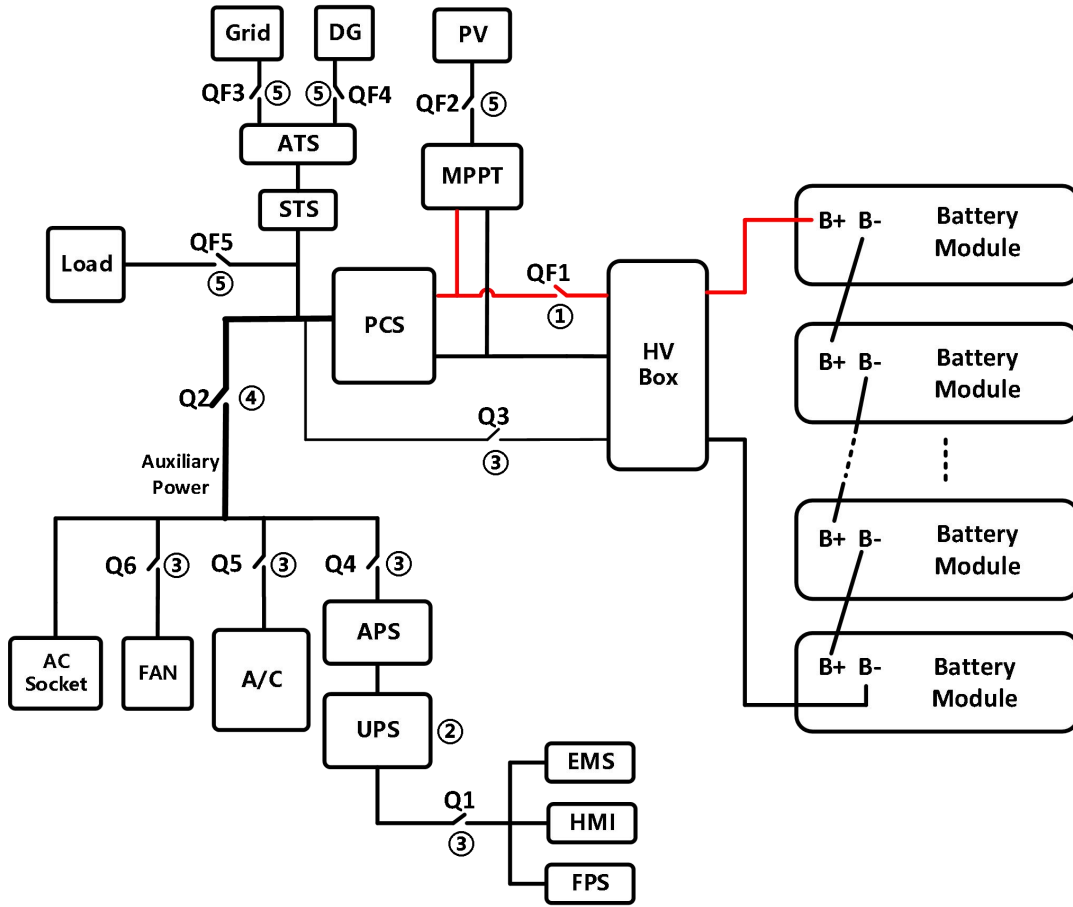

Figure 7-1 Power-off procedure

## 8 Technical Specifications

Model	IYP-215KWH-100KH3M-HP1	IYP-241KWH-100KH3M-HP1
<b>Battery</b>		
Battery type	LiFePO4 Battery	LiFePO4 Battery
Rated energy	215KWh	241KWh
Rated capacity	280Ah	314Ah
Rated voltage	768Vdc	768Vdc
Voltage range	672~864Vdc	672~864Vdc
Max. charge current	200A	200A
Max. discharge current	200A	200A
<b>PV</b>		
Rated power	120kW	
Max. PV voltage	950Vdc	
MPPT voltage range	250~850Vdc	
Max. PV current	200A	
MPPT strings	1 or 4 (default: 1 channel)	
<b>AC (On-grid)</b>		
Rated power	100kVA	
Rated AC voltage	400Vac/230Vac	
Grid connection type	L1/L2/L3/N/PE	
Rated AC frequency	50Hz(47~52Hz)/60Hz (57~62Hz)	
Rated AC current	145A	
Power factor	-1~1	
THDi	<3%	
<b>AC (Off-grid)</b>		
Rated power	100kVA	
Max. power	110kVA	

Rated AC voltage	400Vac/230Vac	
Grid connection type	L1/L2/L3/N/PE	
Rated AC frequency	50Hz/60Hz	
Rated AC current	145A	
Max. AC current	160A	
THDi	<3%	
Unbalance degree	100%	
Over load	1.1 times (10s) 1.25 times (30ms)	
Switch time	<20ms	
<b>General Parameters</b>		
IP degree	IP54	
Topology	Transformerless	
Operating temperature range	-20~55°C (derating@>45°C)	
Fire protection system	Aerosol	
Cooling method	Forced air cooling (PCS), A/C cooling (Battery)	
Max. operating altitude	<2000m	
Communication	RS485/WiFi/4G	
Dimensions(WxDxH)	1590*1050*2085mm	
Weight	2450kg (about)	2550kg (about)

**Note:** PV open voltage must be lower than Max. PV voltage (950Vdc) in the lowest temperature.

---

## 9 Maintenance

### 9.1 Explanation of Terms

- **Normal operating:** Refers to the system that works every day.
- **Intermittent operating:** Refers to a system that does not have a fixed monthly running frequency and cannot guarantee daily work.
- **Long-time unused:** The battery system that has not started working for more than 5 months (the battery system needs to be charged to 50% SOC before being suspended).

### 9.2 Operating Instructions for Normal Operating System

- Perform battery maintenance on the system every twelve months to prevent battery damage. Refer to Section 9.6 for specific maintenance operating method.
- Conduct an inspection of BESS every twelve months (refer to Appendix 1) and make inspection record.

### 9.3 Operating Instructions for Intermittent Operating System

- The operating instructions are the same as those of normal operating system.

### 9.4 Operating Instructions for Long-time Unused System

- SOC range of battery storage: 30%~50%, avoid long-term storage of batteries below 15% SOC. If the battery is not used for a long time, it is necessary to cut off the power-consuming equipment in time.
- Conduct an inspection of BESS every five months (refer to Appendix 1) and make inspection record.
- Perform battery maintenance on the system every five months to prevent battery damage. Refer to Section 9.6 for specific maintenance operating method.

- Before the first usage of long-time unused system, the battery system must be fully charged at least once to activate the battery system in order to recover the battery performance to the best condition.

**Tips**

If the energy storage system is not used for a long time, it will cause irreversible damage to the battery. Please perform regular maintenance.

## 9.5 Function of Battery HV DC Breaker

- The HV DC breaker(QF1) is an electrical component used to manually cut off the high voltage circuit for safety protection (pictured, right).

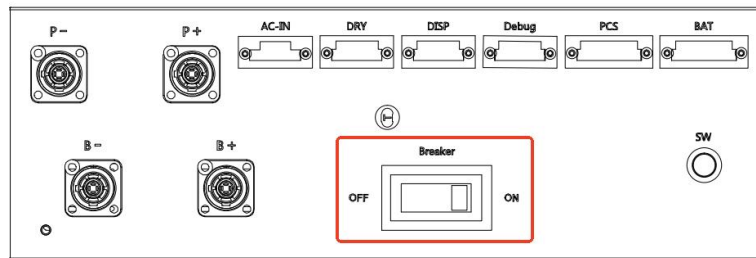

- Before the maintenance work is performed on the system, the relevant personnel must disconnect the HV DC Breaker(QF1). After the maintenance work is completed, ensure that the HV DC breaker is in the ON state.

## 9.6 Operating Method of Battery Maintenance

In order to ensure the long-term safe and reliable operation of your energy storage system, please read and follow the instructions below:

### Maintenance process:

#### Plan 1 This plan is applicable when SOC of the battery system is low

1. Discharge the battery system to the cut-off condition (Average cell voltage < 3.1V or the lowest

voltage < 2.8V), then stop discharging, standing for 1 hour.

2. Full charging automatically to the battery system (The highest voltage>3.65V), after charging, standing for 1 hour.
3. Discharge the battery system to 50% and stop

**Plan 2 This plan is applicable when SOC of the battery system is high**

1. Full charging automatically to the battery system (The highest voltage > 3.65V), after charging, standing for 1 hour.
2. Discharge the battery system to the cut-off condition (Average cell voltage < 3.1V or the lowest voltage < 2.8V), then stop discharging, standing for 1 hour.
3. Charge the battery system to 50% and stop

**Tips**

1. Check to ensure environmental safety, system safety, no alarm, no fault before performing maintenance operations.
- 2.
3. After the battery maintenance of ESS is completed, you can notify our after-sales engineer to perform data analysis for free.

## 9.7 Maintenance Requirements for A/C System

- In case of liquid leakage inside the electric cabinet, please stop the machine in time and contact us for maintenance.
- The energy storage water cooling pipeline uses a liquid level alarm. If the liquid level sensor prompts an alarm, the liquid needs to be added.
- If you purchase the coolant by yourself, you need to choose the coolant with the ice point lower than the local minimum temperature. It is recommended that the concentration of 40% ~ 50% glycol is good for aluminum corrosion resistance, and the maintenance should be carried out according to the requirements of the coolant supplier. It is recommended to increase the maintenance frequency. Any damage to the relevant parts of the electric cabinet caused by the use of other coolants not recommended is not covered by the warranty.



---

## A Crimping OT/DT Terminals

### OT/DT Terminal Requirements

- When a copper core cable is used, a copper terminal must be used.
- When a copper-clad aluminum cable is used, a copper terminal must be used.
- When an aluminum alloy cable is used, a copper-to-aluminum adapter terminal or an aluminum terminal with copper-to-aluminum adapter tab must be used.

---

 Notice

- Do not connect an aluminum terminal directly to the terminal block. Otherwise, electrochemical corrosion may occur, affecting the reliability of cable connection.
  - When a copper-to-aluminum adapter terminal or an aluminum terminal with copper-to-aluminum adapter tab is used, the requirements defined in IEC61238-1 must be met.
  - When a copper-to-aluminum adapter tab is used, the front and back sides shall be identified. The aluminum side of the tab contacts the aluminum terminal and the copper side contacts the terminal block.
-

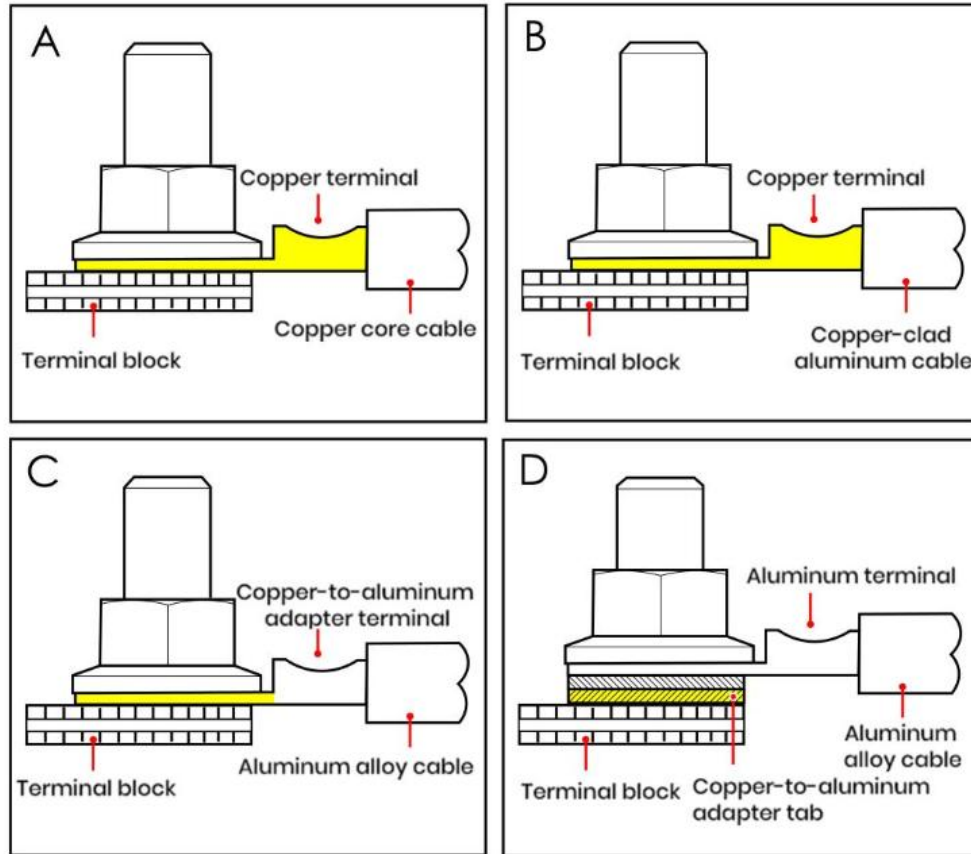
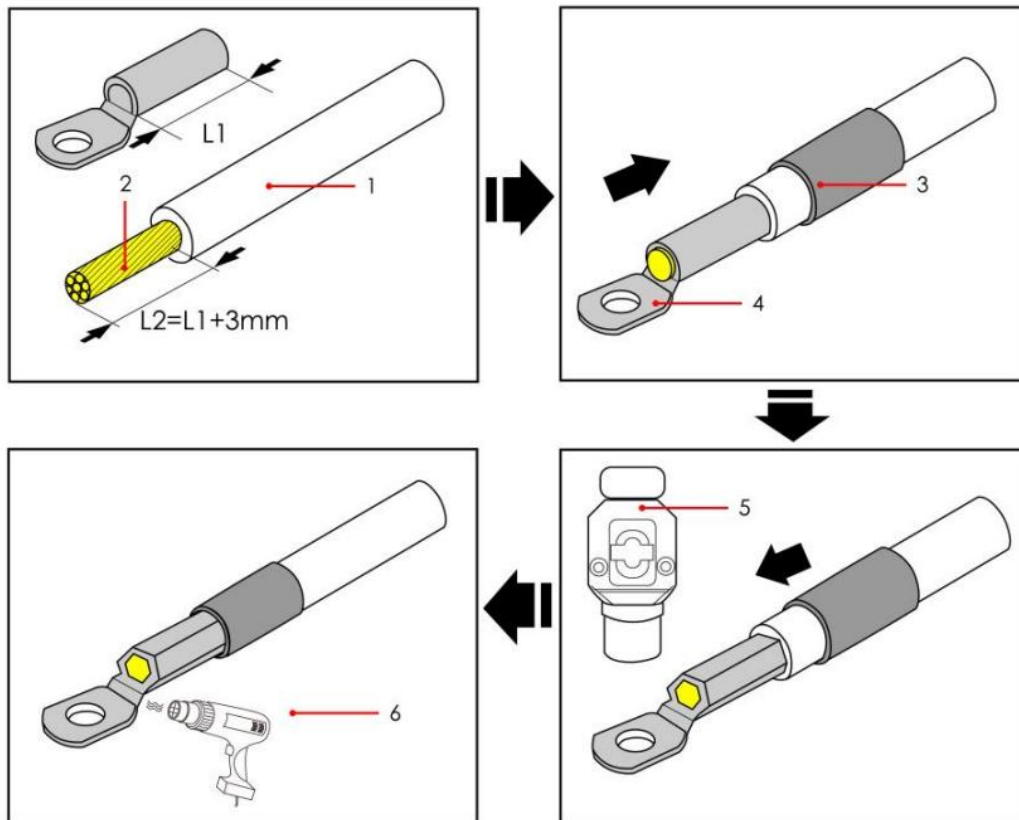

Figure A-1 OT/DT terminal requirements

## Crimping OT/DT Terminals

### ! Notice

- Do not damage the core while stripping.
- The cavity formed after crimping the conductor tab of the OT/DT terminal should completely cover the core, and the core should be tightly bonded to the OT/DT terminal without loosening.
- The crimping point can be covered with heat shrink tubing or insulation tape. Here, the heat shrink tubing is used as an example.
- Take protective measures when using a hot air gun to prevent equipment damage.



**Figure A-2** Crimping DT terminal

(1) Cable

(2) Core

(3) Heat shrink tubing

(4) DT terminal

(5) Hydraulic tongs

(6) Hot air gun

## B How to Repair Paint

### Preconditions

- Do not repair paint in bad weather conditions such as rain, snow, wind, sand storm, without shelter outdoors.
- The paint that meets the requirements has been prepared according to the color palette provided at the time of delivery.

### Important

The equipment appearance shall be in good condition.

Immediately repair paint if any painting defect exists.

#### Description

Visually inspect the painting defect and prepare necessary tools and materials. The number of materials is subject to on-site evaluation for paint repair.

**Table B-1 Paint repair**

Degree of Painting Defect	Tools and Materials	Operation Procedure	Description
Light scratches (The steel sheet substrate is not exposed)	Spray paint or paint, brush (for small-area repainting), fine sandpaper, anhydrous ethanol, cotton cloth, and spray gun (for large area repainting).	Go through step 1, step 2, step 4, and step 5.	1. For the color of the top coating (acrylic paint), refer to the color palette provided at the time of delivery and Pantone color code indicated on the
Stains or rusting that cannot be wiped off			

<p>Deep scratches (The primer is broken and the steel sheet substrate is exposed)</p>	<p>Spray paint or paint, zinc-rich primer, brush (for small-area repainting), fine sandpaper, anhydrous ethanol, cotton cloth, spray gun (for large-area repainting).</p>	<p>Go through step 1, step 2, step 3, step 4, and step 5.</p>	<p>color palette.</p> <p>2. Spray paint or brush painting is recommended for small scratches and small-area stains and rusting.</p>
<p>Logo and pattern defects</p>	<p>For logo or pattern defects, identify the logo size and color code, and then ask a local painting service provider to establish a repainting plan and make repairs according to logo size, color, and defect condition.</p>		<p>3. A spray gun is Recommended for a large number of scratches and large-area stains and rusting.</p>
<p>Pitting</p>	<p>1. When the pitting area is less than 100mm<sup>2</sup> and the depth is less than 3mm, pitting area should be filled with unsaturated polyester resin putty (Poly-Putty base), and then repainted as deep scratches.</p> <p>2. When the pitting area is larger than 100mm<sup>2</sup> and the depth is greater than 3mm, ask your local service provider to put forward a repainting solution according to actual needs.</p>		<p>4. The paint film should be as thin and uniform as possible, the paint film should not be droplet shaped, and the surface should be smooth.</p> <p>5. Rest the painted surface for about 30 minutes before proceeding with subsequent operations.</p>

## Operation Procedure

**Step 1** Gently grind the damaged area with fine sandpaper to remove dirt or rust.

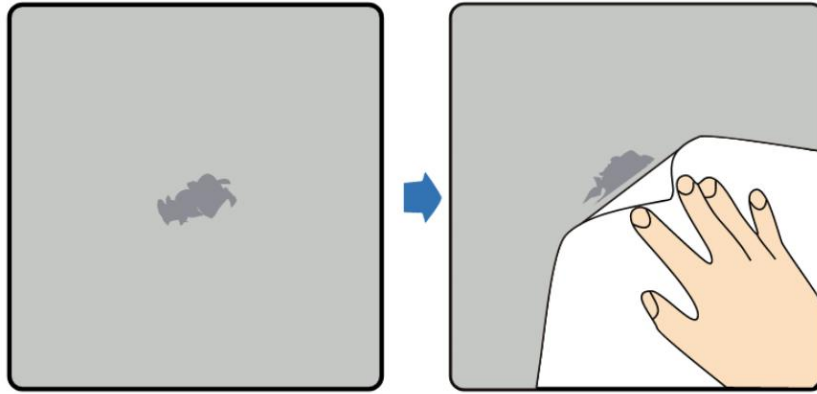

**Figure B-1** Grind the damaged area with fine sandpaper

**Step 2** Wet the cotton cloth with anhydrous ethanol, wipe the sanded area or the area to be repaired to remove surface dirt and dust, and then wipe dry with clean cotton cloth.

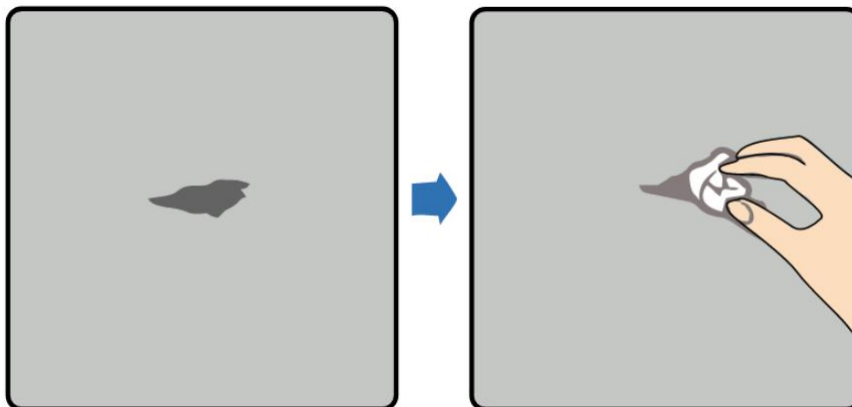

**Figure B-2** Treat the damaged coating with anhydrous ethanol

**Step 3** Apply zinc-rich primer to the damaged area with brush or spray gun

**!** Notice

- If the substrate is exposed in the area to be repaired, an epoxy zinc-rich primer must be applied first until the substrate is not exposed after the paint is dry, and then an acrylic top coating should be applied.

- Select an epoxy zinc-rich primer or an acrylic top coating of the corresponding color according to the top coating color of the equipment.
- 

**Step 4** Select one of the methods of spray painting, brush painting, spray gun spraying according to paint defect degree to evenly repaint the damaged area until the coating defect is not visible.

---

**! Notice**

- It should be noted that the paint film should be as thin and uniform as possible, the paint film should not be droplet shaped, and the surface should be smooth.
  - If the patterns on the equipment use multiple colors, use tape and white paper to cover the parts of other colors other than the damaged paint before repainting to avoid contamination of other color parts during repainting operation.
- 

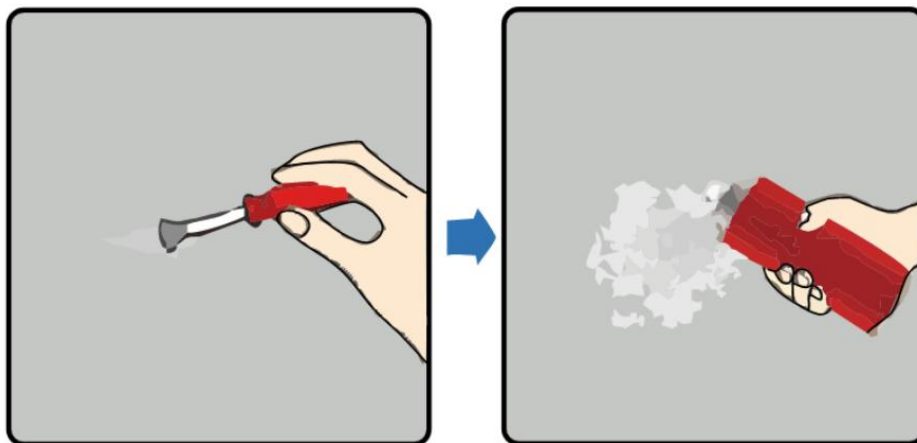

**Figure B-3** Repainting on damaged coating

**Step 5** Upon completion of painting, leave the equipment rest for about 30 minutes, and then

check whether the painting area meets the requirements.

 Description

- The color of the painting area should match that of its surrounding area. Use a colorimeter to measure the color difference. Check that the color difference  $\Delta E$  is not more than 3. If a colorimeter is not available, verify that there is no significant edge between the repainted area and its surrounding area. The painting area should also be free of swelling, scratching, peeling off or cracking.
- For spray painting, it is recommended to spray paint 3 times first, and then check whether the requirements are met. Repeat spraying paint until requirements are met, when necessary.

## C How to Recycle Used Batteries

 Notice

- The Company does not recycle used batteries. The Customer needs to contact their local recycling plants for disposal of used batteries.
- If no local recycling plant is available, the Customer is recommended to contact recycling plants in their nearest countries or regions for disposal of used batteries.

**Step 1** Contact your nearest recycling plant.

**Step 2** The recycling plant evaluates the recycling cost.

**Step 3** The recycling plant recycles used batteries in two ways:

- Door-to-door recycling service: A recycling plant will provide the door-to-door recycling service. This way, however, may incur time or transportation cost.
- Centralized recycling service: The Customer collects all recycled lithium batteries in a designated place and a recycling plant disposes of these used batteries in a centralized manner.

 Description

The transportation cost incurred from the recovery service needs to be borne by the Customer.

**Step 4** The recycling plant has full power to dispose of recycled batteries. The recycling plant has full power to dispose of recycled lithium batteries, without customer engagement.

## D Contact Information

If you have any questions about this product, please feel free to contact us.

**Table D-1** Customer support information

Country or Region	Customer Support Email	Telephone

## F Layout Drawing

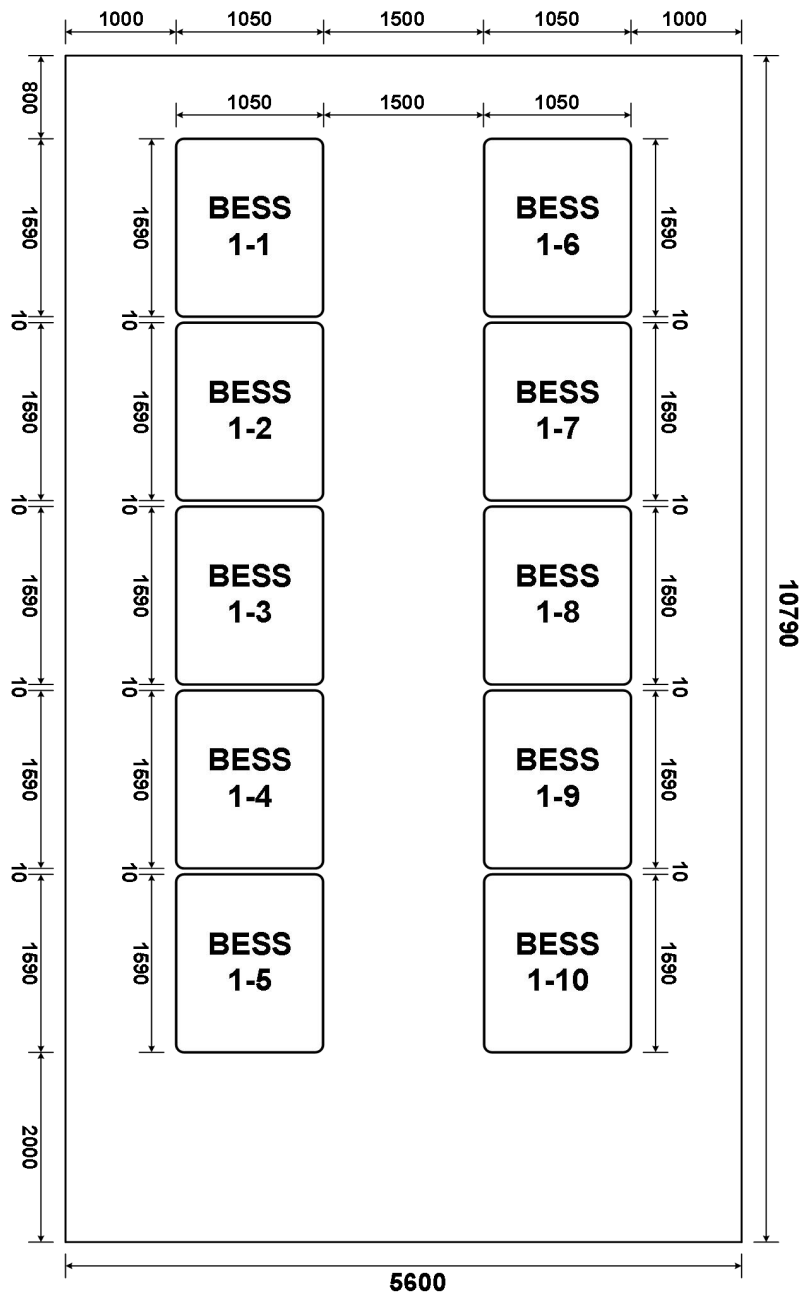

Figure F-1 Installation layout diagram

**! Notice**

- Ensure a distance of at least 1m between the installation location of the equipment and the electrical equipment.
- Ensure that a maintenance channel is reserved on one side, with a width of at least 2m.

## Appendix 1

Inspection project	Method	Yes-√ No-× Not applicable-O	Abnormal record
Is the fire extinguishing system	Visual inspection		
Whether the fire extinguishing system is within the validity period	Visual inspection		
Is the cooling system complete	Visual inspection		
Is the cooling system air duct blocked	Visual inspection		
Whether the appearance of the electric cabinet is deformed	Visual inspection		
Whether the appearance of the electric cabinet is rusted or damaged	Visual inspection		
Is there water vapor inside the electric cabinet	Visual inspection		
Whether the LV harness is loose or damaged	Visual inspection		
Whether the HV harness is loose or damaged	Visual inspection		
Whether the wiring harness interferes with the structural parts	Visual inspection		
Whether the high voltage connection is ablated	Visual inspection		
Whether the fixing bolt of structural parts is loose or missing	Visual inspection		
Is there a foul smell in the battery compartment	Sniffing		
Is there a pungent smell in	Sniffing		

the electric cabinet			
Whether HV connection part has burnt smell	Sniffing		
Is the summary data complete	Monitor master computer		
Is the cell voltage data complete	Monitor master computer		
Is the cell temperature data complete	Monitor master computer		
Whether there is an abnormal alarm in the alarm bar	Monitor master computer		
<p><b>Note: If any abnormalities are found during the inspection, please feedback in time, and contact the relevant personnel for processing.</b></p>			